

**Redegørelse i anledning  
af tre havarier  
med Dash8 Q400**

**Bilag til redegørelsens kap. 6**

**Hæfte 1**



## Bilag

Bilag 01	Havarimeddelelse fra SAS LN-RDK
Bilag 02	AOM 235
Bilag 03	LN-RDK AD Compliance liste
Bilag 04	AOM 236A
Bilag 05	Havarimeddelelse fra SAS LN-RDS
Bilag 06	OPS-udv. Q400 LD bevis inddrages 120907
Bilag 07	EASA info vedr. MLG Collaps Q400 120907
Bilag 08	SAS preliminary engineering analysis LN-RDK
Bilag 09	AOM 237A
Bilag 10A	Bombardier RD84-32-059 Issue 1 120907
Bilag 10B	Goodrich SCR 086-07 rev NC 120907
Bilag 10C	Goodrich Steeing Tool CG56806 120907
Bilag 11	OPS udv till til færgeflynning 130907
Bilag 12	HCLJ foreløbig undersøgelse 130907
Bilag 12A	DHC-8-402 prelim report
Bilag 13	AOM 238
Bilag 14	AOM 239
Bilag 15	AOM 240
Bilag 16	AOM 241A
Bilag 17	AOM 242B
Bilag 18	Bombardier RD84-32-059 Issue 2 130907
Bilag 19	Bombardier RD84-32-059 Issue 3 130907
Bilag 20	Goodrich RD S2116 rev NC
Bilag 21	Goodrich RD S2117 rev NC
Bilag 22	Goodrich SCR 086-07 rev A 130907
Bilag 23	Goodrich SCR 086-07 rev B 130907



# **Bilag 1**





**Aircraft Accident Notification Report  
SK1209/09SEP2007**

**Occurrence**

Information	Specification/Description
Date	09 Sept 2007
Time	1410 UTC
Location	AAL-EKYT Aalborg- Denmark Longitude: 9, 59, 0 E Latitude: 57, 6, 0 N Elevation: 10 ft
Last point of departure	CPH-EKCH (Copenhagen) Off block 1220 UTC Airborne 1232 UTC
Point of Intended Landing	AAL-EKYT TD 1357 UTC
Flight number	SK1209
Radio Call sign	Scandinavian 1209
Type of operations	Commercial
Phase of operation	Landing
Flight level	N/A
Description of the occurrence	Right main landing gear collapsed during touchdown, veered off runway after touchdown.
Fire	Yes
Other	5 passengers light injured.

**Aircraft Information**

Information	Specification/Description
Manufacture	Bombardier Aerospace Inc.
Model	DHC-8-402
Registration	LNRDK Ingrid Viking
Serial number	MSN 4025
Year of manufacture	Date of acceptance 07 OCT 2000 Registered in Norway 11 Oct 2000
Cert. of Airworthiness, exp, date	31 DEC 2007
Total time	Flight Hours: 12141.37 Hrs Cycles: 14795 Eng LH since new: 10253,37 FH 9087 FC Eng RH Since new: 10626.37 FH 12814 FC
Time since last maintenance and type of maintenance	L-Check 2007 09 09 A1 och A2 2007 07 07

Engine(s) type and model	PW 150A
Propeller(s)/rotor(s), manufacture and type	Dowty Aerospace Propellers - R408/6-123-F/1
Total time since last maintenance	<p>LH Engine PN 3121627-01 SN PCE-FA0136  TSI = 1329,37 FH  TSI = 1497 FC  TSN = 11927,03 FH  TSN = 9087 FC  TSMInor = 10253,37 FH  TSMInor = 9087 FC  TSO = 10253,37 FH  TSO = 9087 FC</p> <p>LH Engine PN 3121627-01 SN PCE-FA0006  TSI = 1329,37 FH  TSI = 1497 FC  TSN = 10626,37 FH  TSN = 12814 FC  TSMInor = 1653,37 FH  TSMInor = 1847 FC  TSO = 10626,37 FH  TSO = 12814 FC</p>
Landing Gear	NLG PN 47200-15 SN MAL0011 LH MLG PN 46100-29 SN MA0057 RH MLG PN 46100-29 SN MA0023
Time since last maintenance	NLG TSI = 347,03 FH TSI = 414 FC TSN = 11927,03 FH TSN = 15078 FC TSO = 11927,03 FH TSO = 15078 FC  LH MLG TSI = 12141,37 FH TSI = 14795 FC TSN = 12141,37 FH TSN = 14795 FC TSO = 12141,37 FH TSO = 14795 FC  RH MLG TSI = 12141,37 FH TSI = 14795 FC TSN = 12141,37 FH TSN = 14795 FC TSO = 12141,37 FH TSO = 14795 FC







**Weather details at time of occurrence**

Information		Specification/Description
Wind	Direction	290
	Velocity	08kt
Gust	Direction	
	Velocity	
Turbulence	None/Light	None
	Moderate/severe	
Visibility	Visibility (m) RVR	9999
Temperature	Dew point OAT	18/09
Pressure	QNH	1014
Clouds	Type amount Height	few038 bkn250
Precipitation	None/Rain Drizzle/Snow RASN/Hail	NONE
Intensity	Light/Showers Moderate/Severe	N/A
Icing	None/Light	NONE
Light conditions	Daylight	Yes
General weather in the area	VMC IMC	

SA091350 EKYT 29008kt 260v320 9999 FEW038 BKN250 18/09 Q1014

FC 091221 EKYT 33007kt 9999 FEW035 SCT250 BECMG 1618 27010KT BKN020

NPH Scandinavian Flight Operations	NPH Scandinavian Technical Operations	NPH Scandinavian Ground Operations	NPH Crew Training
Stockholm 09 Sept 2007	Stockholm 09 Sept 2007	Stockholm 09 Sept 2007	Stockholm 09 Sept 2007
			
Ola Reinholdt	Geir Steiro	Tomas Linden	Torben Løvetofte



## **Bilag 2**



## Bombardier Q400

### All Operator Message No. 235

---

---

ATTN: Director/Manager of: Maintenance  
Engineering  
Quality Control  
Flight Operations  
Procurement/Spares

DATE: 09 September 2007

ATA: 0000 MODEL: Q400

SUBJECT: In-Service Incident – Right Main Landing Gear Collapse after Landing

REFERENCE: Preliminary information provided by Operator to Bombardier

The following message is being sent to all Bombardier Aerospace Regional Aircraft Q400 Operators and Bombardier Aerospace Regional Aircraft Field Service Representatives.

This message contains information requiring attention and/or action. Please ensure timely and appropriate distribution within maintenance and flight operations departments.

---

---

#### DISCUSSION:

This All Operator Message is being issued to advise Operators of an incident that has recently occurred on a Dash 8 Q400 aircraft. Following normal touchdown, the right main landing gear collapsed, the aircraft departed the right side of the runway and came to rest on the right wing and nacelle. There was a post-occurrence that was extinguished by airport Crash Fire Rescue. There were some minor injuries reported.

Bombardier Aerospace, Air Safety will plan to dispatch to the scene and assist the local Aircraft Accident Investigation Board during their investigation.

Pending completion of the investigation by authorities, Bombardier cannot comment on either the circumstances surrounding this accident, or speculate as to possible causes. However, this is the first incident on the Q400 where the main landing gear has collapsed, following a landing. Operators will be updated, once further details become available.

Please direct responses and inquiries to the Technical Help Desk in Toronto at telephone (416) 375-4000 or facsimile (416) 375-4539 or e-mail: [thd.gseries@aero.bombardier.com](mailto:thd.gseries@aero.bombardier.com)

Alisa Turk, Manager, Technical Help Desk, and Martin Elliott, Director, In-Service Engineering Systems & Technical Support, Bombardier Aerospace Regional Aircraft.





## **Bilag 3**





**Airworthiness Directives  
Compliance Status  
Airframe / Appliance / Engine / Propeller / APU**

**LN-RRW**  
 Model: B737-800  
 TT A/C: 4417 H  
 TC A/C: 2136 C  
 Date from: Mfg Date:  
 Line/Cust No: 32277  
 MSN:

AD-Number Effective Date	Para & Sub	Subject / Compliance	Method of Compliance		Accompl. Status	Additional Information
			External Ref	Action Ref		
FAA-2001-10-14/737	08JUN2001	<p><b>Subject:</b> TO FIND AND FIX INCORRECT INSTALLATION OF THE RELEASE PIN IN THE GENERATOR FIRING MECHANISM OF THE CHEMICAL OXYGEN GENERATOR</p> <p><b>Compliance:</b> WITHIN 90 DAYS AFTER THE EFFECTIVE DATE REPETITIVE INSPECTION, REF MR 3522013 (STK LETTER 2001-0430-1072)</p> <p><b>NOTE:</b> MR 3522013(REPETITIVE)AMM UPDATED,MOVEX RECEIV. INSP INFO IN EFFECT</p>	B737 3522000103			Related AD: SLV-2001-185-767(D)/737
(a)(b)		<p><b>Subject:</b> inspection of chemical oxygen generator</p> <p><b>Compliance:</b> Within 90 D from effective date of AD. Thereafter repeat inspection each 18 M (ref STK Letter 2001-0430-1072).</p>	EO-B737-350007	N/A		Applicability: 737-600, -700, line nr 1 through 784
①	②	③	④	⑤	⑥	⑦

① AD-number and effective date.

② Paragraph and sub-paragraph in the AD.

③ A brief description about the subject of the AD.

④ Referenced document (Manufacturer's Service Bulletins etc.) in the AD.

⑤ SAS issued documents related to the AD. Modifications and Inspections (one time and first repetitive) are always carried out via an EO. Additional repetitive inspections can be accomplished by the EO being repetitive or be included in the Maintenance Program (in such a case they are carried out via a Maintenance Task, i.e. B737-35020).

⑥ Accomplishment status. Terminating Actions are given by date of accomplishment. Repetitive actions are given data for the last time performed and the next due according to the requirement.

⑦ The remark field contains information such as compliance data, repetitive interval, airplane applicability and AD-supersede information.



**Airworthiness Directives  
Compliance Status  
Airframe / Appliance / Engine / Propeller / APU**

**LN-RDK**

Model: Q400  
TT A/C: 10457 H  
TC A/C: 12914 C  
Date from:

Mfg Date: 07OCT2000

MSN: 4025

AD-Number Effective Date	Para & Sub	Subject / Compliance	Method of Compliance		Accompl. Status	Additional Information	
			External Ref	Action Ref		Complied	Next Due
FAA-74-08-09:R2/Q400 29JUL1996		<p><b>Subject:</b> New placards. No smoking announcement, new ashtrays and fire prevention in lavatories. inspect waste compartment door each 1000 H</p> <p><b>Compliance:</b> Before accumulation of any time in service for new A/C and insp each 1000 flight hours</p>					<b>AIRFRAME</b>
(a)		<p><b>Subject:</b> Install placards.</p> <p><b>Compliance:</b> Within 60 days after August 6, 1974 (the effective date of AD 74-08-09, amendment 39-1917), or before the accumulation of any time in service on a new production aircraft after delivery, whichever occurs later.</p>				<p><b>Applicability:</b> All</p> <p><b>Remarks:</b> As per type design.</p>	
(c)		<p><b>Subject:</b> Install a self-contained, removable ashtrays.</p> <p><b>Compliance:</b> Within 180 days after August 6, 1974, or before the accumulation of any time in service on a new production aircraft, whichever occurs later</p>				<p><b>Applicability:</b> All</p> <p><b>Remarks:</b> As per type design.</p>	
(e)		<p><b>Subject:</b> Inspect all lavatory paper and linen waste receptacle enclosure access doors and disposal doors for proper operation, fit, sealing, and latching for the containment of possible trash fires.</p> <p><b>Compliance:</b> Within 30 days after August 6, 1974, and thereafter at intervals not to exceed 1,000 H since last inspection.</p>	Q400 651	8788 FH	11288 FH	<p><b>Applicability:</b> All</p> <p><b>Remarks:</b> Re: Bombardier MRB task 254000-201 at SA The Q400 MRB is approved by Transport Canada/FAA/JAA, and the SAS Q400 Maintenance Program, based upon the MRB was approved by STK on 03FEB-2000.</p>	
LFV-2853/Q400 23MAR1998		<p><b>Subject:</b> Periodic functional control of emergency exit doors</p> <p><b>Compliance:</b> See action note</p>	Q400 254000-201			<p><b>Action Taken:</b> NOT APPLIC</p> <p><b>Action Note:</b> Periodic FUC of emergency exit door handles covered by MRB 52-21-00-XXX, 52-22-00-XXX, 52-23-00-XXX and others</p>	
LTN-2000-071A/Q400 15NOV2000		<p><b>Subject:</b> VHF FM interference immunity requirements for ILS/LLZ/VOR and VHF/COMradio equipment, as described in JAR OPS 1/ JAR OPS 3</p> <p><b>Compliance:</b> 01jan01</p>				<p><b>Action Taken:</b> NOT APPLIC</p> <p><b>Action Note:</b> Q400 Meets the requirements as per design</p> <p><b>Related AD:</b> SLV-2000-112-430:R2</p>	
LTN-2000-074/Q400 20NOV2000		<p><b>Subject:</b> Kontroll av transponder reported altitude 05dec00</p> <p><b>Compliance:</b> See CAA AD 002-12-99 Rev.1, which this LTN/LDP is based upon</p>				<p><b>Action Taken:</b> NOT APPLIC</p> <p><b>Action Note:</b> SAS Q400 do not use Gilham Format for altitud data to the ATC transponder. (Airdata are supplied via 429-buses)</p> <p><b>Related AD:</b> CAA-002-12-99:R1</p>	
LTN-2003-066/Q400 19SEP2003		<p><b>Subject:</b> DOORS - Change flight compartment door</p> <p><b>Compliance:</b> 01Nov03 NOTE: KTO-255079 (Ensure Operational procedures in JAR-OPS-1.1255(c). KTO-255097)(Ensure compliance of</p>	EO-Q400-250072	EO-Q400-250074	EO-Q400-250075	<p><b>Related AD:</b> JAR-OPS-1.1255</p>	



**Airworthiness Directives  
Compliance Status  
Airframe / Appliance / Engine / Propeller / APU**

**LN-RDK**  
Model: Q400  
TT A/C: 10457 H  
TC A/C: 12914 C  
Date from:

Mfg Date: 07OCT2000  
MSN: 4025

AD-Number Effective Date	Para & Sub	Subject / Compliance	Method of Compliance		Accompl. Status		Additional Information
			External Ref	Action Ref	Complied	Next Due	
SLV-2000-230-434:R1/Q400 05OCT2000		AFM supplement) MTO-255067 (installation) The "Q400 2510000005" inspects cockpit door support structure and attaching hardware for fatigue cracking check the door hinge blocks and dead bolt assy for damage, wear and cracking <b>Subject:</b> ATC tests and inspections IAW FAA PART 43 APP.F amendment 43-31 <b>Compliance:</b> See AD paragraph 1-3 05dec00		Q400 2510000005 Q400 C1-CHECK	7874 FH	12874 FH	Related AD: L TN-2000-074 AD Supersedes: SLV-2000-230-434/Q400
1		<b>Subject:</b> Initial Test of transponder parameters IAW FAA Part 43, Appendix F, Amdt 43-31 paragraph a) through j) <b>Compliance:</b> 05DEC2000		EO-Q400-340007	07OCT2000		
2		<b>Subject:</b> Repetitive inspection. of transponder parameters IAW FAA Part 43, Appendix F, Amdt 43-31 paragraph a) through j) <b>Compliance:</b> 2 year interval.		Q400 443A Q400 3454000001		26MAY2007	
3		<b>Subject:</b> Terminating action is to have the check incorporated into the Maintenance Program					Remarks: MR3454001 incorporated
SLV-2000-264-435:R1/Q400 05OCT2000		<b>Subject:</b> Barometric altitude system, incl reporting part of transponder, inspection and test IAW FAA PART 43 APP. E amendment 43-31 <b>Compliance:</b> 05dec00					AD Supersedes: SLV-2000-264-435/Q400
1 thru 3		<b>Subject:</b> Test of Barometric parameters IAW FAA Part 43, Appendix E, Amdt 43-31, less paragraph (b)(v), (c) and (d). <b>Compliance:</b> 05DEC2000 or at delivery then at 2 year interval.		EO-Q400-340011 Q400 567 Q400 341100-202	06OCT2000 10036 FH	10636 FH	Remarks: Terminating action is to have the check incorporated into the Maintenance Program
SLV-2005-466/Q400 04NOV2005		<b>Subject:</b> Fire Containment requirements for galley equipment <b>Compliance:</b> 2005-11-05. This Cancels the SLV-98-298-406:R1/Q400 as per 04NOV05 NOTE: Removal of waste cart and ship to CPHTP-C for modification. MTO-254375 (Installation of modified waste cart)		EO-Q400-250024	08MAR2001		AD Supersedes: SLV-98-298-406:R1/Q400
TCA-CF-2001-14 04MAY2001		<b>Subject:</b> Fuel tank lightning protection <b>Compliance:</b> See AD paragraphs					Related AD: SLV-2001-122-123
A		<b>Subject:</b> Fuel Tank Vent Line - addition of Teflon tube for insulation, this to improve lightning strike protection. <b>Compliance:</b> 120 days after Eff.Date	BOMBARDIER-SB84-28-02	EO-Q400-280003	10APR2001		
B		<b>Subject:</b> Retrofit of Fuel Probes 1, 2 and 5. <b>Compliance:</b> Latest 4000 Hrs after Eff.Date	BOMBARDIER-SB84-28-01	EO-Q400-280002	10APR2001		Remarks: ModSum 4-113192.
TCA-CF-2001-1		<b>Subject:</b> Main LDG procedure					Related AD: SLV-2002-235-128 FAA-2004-14-15



**Airworthiness Directives  
Compliance Status  
Airframe / Appliance / Engine / Propeller / APU**

**LN-RDK**  
Model: Q400  
TT A/C: 10457 H  
TC A/C: 12914 C  
Date from:

Mfg Date: 07OCT2000  
MSN: 4025

AD-Number Effective Date	Para & Sub	Subject / Compliance	Method of Compliance		Accompl. Status		Additional Information
			External Ref	Action Ref	Completed	Next Due	
16/R1 11JUL2002		<b>Compliance:</b> See AD paragraphs					<b>AD Supersedes:</b> TCA-CF-2001-16
A		<b>Subject:</b> Replace the LH and RH main landing gear downlock proximity sensors with improved version by incorporating retrofit <b>Compliance:</b> Prior to 31 December 2002.	BOMBARDIER-SB84-32-09 BOMBARDIER-SB84-32-09	EO-COMP-320001 EO-Q400-320009	N/A 20JUN2002		<b>Remarks:</b> ModSum 4& 8209;113331
B		<b>Subject:</b> With either production Modsum 4& 8209;113330 or retrofit Modsum 4- 113331 incorporated, the procedures previously added by Airworthiness Directive CF-2001-16, to Section 4.21 of the Aircraft Flight Manual, PSM 1& 8209;84& 8209;1A (Models 400, 401, & 402), are no longer required and are to be removed <b>Compliance:</b> When MTO 321246B are performed on all a/c, latest 30DEC2002	BOMBARDIER-SB84-32-09	EO-Q400-320027	09AUG2002		<b>Remarks:</b> The AFM amendment was added to the AFM and Crew informed law MTO 321240 with ref to AD TCA-CF-2001-16 with deadline 18MAY2001
C		<b>Subject:</b> Inform all flight crews of this change to the AFM <b>Compliance:</b> When MTO 321246B are performed on all a/c, latest 30DEC2002	BOMBARDIER-SB84-32-09	EO-Q400-320027	09AUG2002		
D		<b>Subject:</b> Accomplishment of paragraphs A, B, and C is considered terminating action to this directive <b>Compliance:</b> Ref Part A, B and C					
TCA-CF-2001-23 20JUL2001		<b>Subject:</b> Revision of maintenance requirements for AFT pax door stops and AFT baggage door stops due to fatigue issues <b>Compliance:</b> Within 30 days after effective date of this AD		EO-Q400-510001	10JUL2001		
Note				Q400 558-2 Q400 523004F101 Q400 558-2-T Q400 523004F101 Q400 570 Q400 521004F101 Q400 570-T Q400 521004F101 Q400 618 Q400 532061F101 Q400 618-T Q400 532061F101	12743 FC 12993 FC INACTIVE 18194 FC INACTIVE 18194 FC		<b>Applicability:</b> Those MR's has been terminated due to modifications, ref MPD Temp Rev ALI-34 of 30MAR2004. 5230024 replaced by 5230025. Ref MTO 520405 5210024 replaced by 5210025. Ref MTO 520400 5320059 is terminated. Ref MTO 530953 5320057 replaced by 5320186. Ref MTO 530916 & 530953
TCA-CF-2001-44 28DEC2001		<b>Subject:</b> Spoiler lift dump valve, inspection for PN and replacement of named SN's <b>Compliance:</b> See AD paragraphs 13feb02					<b>Related AD:</b> FAA-2004-16-13
1.A		<b>Subject:</b> Determine through a visual inspection of the aircraft, the serial number of the four spoiler lift dump valves (Part Number 395800-	BOMBARDIER-SB84-27-12	EO-Q400-270014	02OCT2001		<b>Applicability:</b> If the serial number of any spoiler lift dump valve is in the range from 5164 through 5264 or from 5267 through 5279 (below referred to as the



**Airworthiness Directives  
Compliance Status  
Airframe / Appliance / Engine / Propeller / APU**

**LN-RDK**  
Model: Q400  
TT A/C: 10457 H  
TC A/C: 12914 C  
Date from:

Mfg Date: 07OCT2000  
MSN: 4025

AD-Number Effective Date	Para & Sub	Subject / Compliance	Method of Compliance		Accompl. Status	Additional Information
			External Ref	Action Ref		
		1005) installed in each aircraft <b>Compliance:</b> Within 45 days after effective date.				suspect range), perform paragraph 1.B before further flight.
1.B (i), (ii), (iii)		<b>Subject:</b> (i) Replace the suspect spoiler lift dump valve with a valve that has a S/N that is outside the suspect range; or, (ii) Replace the suspect spoiler lift dump valve with a valve that has had the manufacturing defect corrected. Valves which have had the defect corrected are identified with S/N that includes the suffix "A" (e.g. S/N 5164A); or, (iii) Advise flight crew of Accelerate-Stop and Landing Distance performance penalty below and incorporate this performance change in the AFM. <b>Compliance:</b> If a suspected spoiler lift dump valve is found; before further flight	BOMBARDIER-SB884-27-12	EO-Q400-270015	N/A	<b>Remarks:</b> Part 3 of MTO 270925; Amend operational restrictions to aircraft LN-RDT74038 (aw AD Note TCA-CF-2001-44 Part 1.B.iii Part 4 of MTO 270925; Upon completion of Spoiler Lift Dump Valve replacement, remove Operational Restrictions set forth above.
2		<b>Subject:</b> Replace all spoiler lift dump valves that have a serial number in the range from 5164 through 5264 or from 5267 through 5279 that have not yet been replaced in accordance with paragraphs 1.B (i) or (ii) above. Concurrently, remove the amendment to the AFM that was inserted in accordance with paragraph 1.B (ii) of this directive. <b>Compliance:</b> Within 6 months after the effective date of this AD	BOMBARDIER-SB884-27-12	EO-Q400-270015	N/A	
3		<b>Subject:</b> Do not install spoiler lift dump valves with a serial number that is in the suspect range 395800-27-229 on any aircraft unless the manufacturing defect has been corrected. These corrected valves are identified with a serial number that includes the suffix "A" (e.g. S/N 5164A) <b>Compliance:</b> As of the effective date of this AD.	PARKER-395800-27-229	EO-COMP-270003	N/A	<b>Remarks:</b> Valves are to be sent to Parker Aerospace for modification and checked upon arrival to SAS. This ensures that no S/N in the range are allowed to enter store.
TCA-CF-2002-07 04MAR2002		<b>Subject:</b> FWD engine mounts assembly <b>Compliance:</b> See AD paragraphs		EO-COMP-710002R01	N/A	<b>Related AD:</b> FAA-2002-07
1		<b>Subject:</b> Perform a visual inspection to determine the part number and the configuration for the four (4) forward engine mount assemblies in accordance with Bombardier Alert Service Bulletin A84-71-06 Rev A or later revisions. <b>Compliance:</b> Within 100 flight cycles after the effective date of this AD		EO-COMP-710002	96042-09 0321-28FEB2002 96042-10 2758-26MAR2002 96042-09 0222-02MAR2002 29NOV2001 12MAR2002	<b>Remarks:</b> KTO-710373 was issued prior to AD KTO-710382 checks spares
2		<b>Subject:</b> Any engine mount assemblies found cracked are to be replaced with the production engine mount assemblies (P/N 96042-09) prior to further flight.	BOMBARDIER-SB884-71-06	EO-Q400-710003 EO-Q400-710006	29NOV2001 12MAR2002	<b>Remarks:</b> KTO-710373 was issued prior to AD



**Airworthiness Directives  
Compliance Status  
Airframe / Appliance / Engine / Propeller / APU**

**LN-RDK**  
Model: Q400  
TT A/C: 10457 H  
TC A/C: 12914 C  
Date from: MSN: 4025

Mfg Date: 07OCT2000

AD-Number Effective Date	Para & Sub	Subject / Compliance	Method of Compliance		Accompl. Status		Additional Information
			External Ref	Action Ref	Complied	Next Due	
TCA-CF-2002-13:R2 17JUN2005	3	<b>Subject:</b> Before further flight <b>Subject:</b> Installation of all four forward engine mounts with the production engine mount assemblies (P/N 96042-09) terminates the repetitive inspection requirements of this directive	BOMBARDIER-SB84-71-06	EO-Q400-710003 EO-Q400-710006	29NOV2001 12MAR2002		Remarks: KTO-710373 was issued prior to AD
	4	<b>Subject:</b> As of the effective date of this directive, pre-production engine mount assembly (P/N 96042-07) shall not be installed on any aircraft as replacement. Replacement of pre-production engine mount assembly may be achieved either by direct replacement with the -09 configuration or by the rework of the -07 assembly in accordance with Part B of the Accomplishment Instructions of the above-mentioned Alert Service Bulletin. <b>Compliance:</b> Before 04MAR2002		EO-COMP-710002	96042-09 0321:28FEB2002 96042-10 2758:26MAR2002 96042-09 0222:02MAR2002		Remarks: KTO-710382 checks spares
		<b>Subject:</b> MLG uplock assembly <b>Compliance:</b> PART I: MTO-321287 EFFDATE 2005-06-17 PART II: MTO-321288 EFFDATE 2005-06-17 NOTE: R2 provides all insp requirement for 46500-5, lib lifelimt as per R1 Introduction PN 46500-7 is considered TERMINATING ACTION					<b>Related AD:</b> SLV-2005-226 <b>AD Supersedes:</b> TCA-CF-2002-13:R1
	Info	<b>Subject:</b> Modifications: <b>Compliance:</b> At shopvisit					<b>Applicability:</b> P/N 46500-3 <b>Remarks:</b> Modification of P/N 46500-3 to 46500-5
	Info 2	<b>Subject:</b> Modification: <b>Compliance:</b> At Shopvisit	BOMBARDIER-SB84-32-29	EO-COMP-320003	46500-7 MAL-0002:20SEP2004		<b>Applicability:</b> P/N 46500-3 and 46500-5 <b>Remarks:</b> Modification of P/N 46500-3 and 46500-5 to 46500-7
	Part I	<b>Subject:</b> Amend AFM 1-84-1A section 4-21-1 Advice crew <b>Compliance:</b> Within 3 days from effective date.		EO-Q400-320017	06FEB2002		<b>Applicability:</b> MSN 4001 and subsequent.
	Part II A.1	<b>Subject:</b> Replace Uplock unit <b>Compliance:</b> Before accumulating 2500H or 3000C whichever comes first. For uplock unit above those limitation, within 14 days from effective date.	BOMBARDIER-SB84-32-15	EO-Q400-320018	28FEB2002		<b>Applicability:</b> MSN 4001 and subsequent with Uolock Assembly P/N 46500-3 and 46500-5.
	Part II A.2	<b>Subject:</b> Replace Uplock unit <b>Compliance:</b> At 2500H/3000C interval	BOMBARDIER-SB84-32-15	EO-Q400-320018	28FEB2002		<b>Applicability:</b> MSN 4001 and subsequent with Uolock Assembly P/N 46500-3 and 46500-5. <b>Remarks:</b> KN 843224 demand; CBB: 3000 & HBB: 2500 PN 46500-3 shall be replaced.
	Part II B.1	<b>Subject:</b> Insp Uplock Roller iaw A84-32-15 <b>Compliance:</b> Within 30 days from effective date.	BOMBARDIER-SB84-32-15	EO-Q400-320016	28FEB2002		<b>Applicability:</b> MSN 4001 and subsequent.
	Part II B.2	<b>Subject:</b> Replace Uplock Roller not having inner friction liner with P/N 46575-1 <b>Compliance:</b> Within 30 days from effective date.	BOMBARDIER-SB84-32-15	EO-Q400-320018	28FEB2002		<b>Applicability:</b> MSN 4001 and subsequent.





**Airworthiness Directives  
Compliance Status  
Airframe / Appliance / Engine / Propeller / APU**

**LN-RDK**  
Model: Q400  
TT A/C: 10457 H  
TC A/C: 12914 C  
Mfg Date: 07OCT2000  
MSN: 4025

AD-Number Effective Date	Para & Sub Part II C	Subject / Compliance	Method of Compliance		Accompl. Status	Additional Information
			External Ref	Action Ref		
	Part II C.1	<p><b>Subject:</b> Part II C Inspection of P/N 46500-5 Up-lock Assemblies.</p> <p><b>Subject:</b> Inspection of P/N 46500-5 Up-lock Assemblies: inspect the surface of the up-lock latch lower jaw for the presence of a wear groove and measure the wear groove depth to a 0.001 inch accuracy in accordance with DHC-8 Series 400 AMM, PSM 1-84-2, Task 32-31-21-220-801. If the groove depth exceeds 0.007 inches, replace the up-lock assembly with a new or overhauled P/N 46500-7 up-lock assembly as per instructions given in Chapter 32-31-21 of the AMM PSM 1-84-2.</p> <p><b>Compliance:</b> Prior to the up-lock assembly accumulating 2500 hours air time or 3000 flight cycles, whichever occurs first; and thereafter, at intervals not exceeding 400 hours air time or 480 flight cycles, whichever occurs first.</p>	BOMBARDIER-SB84-32-15	EO-Q400-320018	28FEB2002	<p><b>Applicability:</b> 1st inspection law KTO 321288, then law KN 843224 demand / P601</p> <p><b>Remarks:</b> P601 entry: P/N 46500-7 has no replacement limit or repetitive inspection Requirement - AD-CF-2002-13R2</p>
	Part II C.2	<p><b>Subject:</b> Inspect the up-lock roller, P/N 46575-1, to ensure that it rotates freely. If the uplock roller does not rotate freely, replace the up-lock roller with a roller of the same part number, as per instructions given in Chapter 32-31-21 of the AMM PSM 1-84-2.</p> <p><b>Compliance:</b> Prior to the up-lock assembly accumulating 2500 hours air time or 3000 flight cycles, whichever occurs first; and thereafter, at intervals not exceeding 400 hours air time or 480 flight cycles, whichever occurs first.</p> <p><b>Subject:</b> Terminating Action. Replacement of both left and right up-lock assemblies with P/N 46500-7 up-lock assemblies terminates the Part I Air Operator Action and Part II Maintenance Action of this directive.</p> <p><b>Compliance:</b> No deadline</p>	BOMBARDIER-SB84-32-15	EO-Q400-320018	28FEB2002	<p><b>Applicability:</b> 1st inspection law KTO 321288, then law KN 843224 demand / P601</p> <p><b>Remarks:</b> P601 entry: P/N 46500-7 has no replacement limit or repetitive inspection Requirement - AD-CF-2002-13R2</p>
	Part III	<p><b>Subject:</b> Terminating Action. Replacement of both left and right up-lock assemblies with P/N 46500-7 up-lock assemblies terminates the Part I Air Operator Action and Part II Maintenance Action of this directive.</p> <p><b>Compliance:</b> No deadline</p>	BOMBARDIER-SB84-32-29	EO-COMP-320003	46500-7 MAL-0002:20SEP2004	<p><b>Applicability:</b> All A/C</p> <p><b>Remarks:</b> TO 321387 marked with a date (completed) or N/A indicates that a P/N 46500-7 is installed.</p>
TCA-CF-2002-15 15MAR2002		<p><b>Subject:</b> Aileron/Rudder Trim panel rework of wiring at rudder switch and special inspection for chafe damages (MODSUM 4-126256)</p> <p><b>Compliance:</b> Part A &amp; B: MTO-270952 and 270967 12Jun02</p>				
A.		<p><b>Subject:</b> Modify the wiring for the rudder trim switch (2722-S2) by incorporating Modsum 4-126256.</p> <p><b>Compliance:</b> Within 90 days from effective date.</p>	BOMBARDIER-SB84-27-13	EO-Q400-270018	27JAN2002	<p><b>Applicability:</b> Aircraft S/N 4005, 4006, 4008 through 4016, 4018 through 4058.</p> <p><b>Remarks:</b> The Aileron/Rudder Trim Panel changes P/N when the panel have been reworked. The rework of the panel was done with reference to initial issue of the referred Service Bulletin. To fulfill all aspects of the referred AD Note, it is necessary to reidentify the panel using a separate Technical Order (MTO-270967). KN 842766 created</p>

OK



**Airworthiness Directives  
Compliance Status  
Airframe / Appliance / Engine / Propeller / APU**

**LN-RDK**  
Model: Q400  
TT A/C: 10457 H  
TC A/C: 12914 C  
Date from:

Mfg Date: 07OCT2000  
MSN: 4025

AD-Number	Effective Date	Para & Sub	Subject / Compliance	Method of Compliance		Accompl. Status		Additional Information
				External Ref	Action Ref	Complied	Next Due	
TCA-CF-2002-25 31MAY2002		B.	<p><b>Subject:</b> Visually inspect all wiring on the back of the aileron/rudder trim control panel (P/N 82410608&amp; 8209;001, -003 or -005) for chafing.</p> <p><b>Compliance:</b> Within 90 days from effective date. Replace any chafed wires before further flight.</p>	BOMBARDIER-SB84-27-13	EO-Q400-270018	27JAN2002		<p><b>Applicability:</b> Aircraft S/N 4005, 4006, 4008 through 4016, 4018 through 4058.</p> <p><b>Related AD:</b> SLV-2002-166-126</p>
		Part A	<p><b>Subject:</b> Modification of auto (PART A) and manual (PART B) pitch trim control due to possibility for loss of A/P pitch trim</p> <p><b>Compliance:</b> PART A; AUTOTRIM: SEE MTO-220297/220298 - LATEST 30JUL02 PART B; MANUAL TRIM; SEE MTO-270961/270960 - LATEST 30JAN03</p>	THALES-C12429A-22-003	EO-COMP-220001	N/A		<p><b>Remarks:</b> For interim procedure, ref SL DH8-400-SL-22-001D (08NOV01).</p>
TCA-CF-2003-28 09JAN2003		Part B	<p><b>Subject:</b> Upgrade of Flight Control Electronic Control Unit FCECU KN 842701 replaced with new KN 842765</p> <p><b>Compliance:</b> 30JAN-2003</p>	PARKER-398500-27-235	EO-COMP-270004	N/A		<p><b>Remarks:</b> For interim procedure, ref SL DH8-400-SL-003 (22MAY01)</p>
		Part 1	<p><b>Subject:</b> Fuselage bottom skin and NO 2 VHF antenna support structure, inspection and rework</p> <p><b>Compliance:</b> PART 1; perf., PART 2; see MTO-531005, PART 3; KTO-531100 + MR5320025PART 4; MTO-531075 / 531005 / 531104 - see TOS for details</p>	BOMBARDIER-SB84-27-14	EO-Q400-270020	20JAN2003		<p><b>Related AD:</b> SLV-2003-368-124</p>
TCA-CF-2003-28 09JAN2003		Part 1	<p><b>Subject:</b> Check records to determine if Bombardier-IS4Q-5300001 or Bombardier-RD8/4-53-317 has been carried out</p> <p><b>Compliance:</b> FOR AIRCRAFT WITH 1.450 hrs or less - INITIAL COMPLIANCE Prior to exceeding 1.900 hours air time Greater than 1.450 but less than or equal to 2.200 - Within 300 hours air time after the effective date of this directive Greater than 2.200 but less than or equal to 3.000 - Within 150 hours air time after the effective date of this directive Greater than 3.000 - Within 50 hours air time after the effective date of this directive</p>					
		Part 2	<p><b>Subject:</b> If Bombardier-IS4Q-5300001 or Bombardier-RD8/4-53-317 has been carried out, carry out TERMINATING ACTION FOR INSP as per Part 4</p> <p><b>Compliance:</b> as per Part 4</p>					
		Part 3 (a)	<p><b>Subject:</b> if neither Bombardier-IS4Q-5300001 nor Bombardier-RD8/4-53-317 has been carried</p> <p><b>Compliance:</b> as per Part 4</p>		EO-Q400-530034	09MAR2003		



**Airworthiness Directives  
Compliance Status  
Airframe / Engine / Propeller / APU**

**LN-RDK**  
Model: Q400  
TT A/C: 10457 H  
TC A/C: 12914 C  
Date from:

Mfg Date: 07OCT2000  
MSN: 4025

AD-Number Effective Date	AD-Number Para & Sub	Subject / Compliance	Method of Compliance		Accompl. Status		Additional Information	
			External Ref	Action Ref	Completed	Next Due		
TCA-CF-2004-07 28MAY2004	Part 3 (b)	out, carry out DVI of External Surface <b>Compliance:</b> Prior to further flight, following the Part 1, i.e. latest 50 hrs after 09JAN04  <b>Subject:</b> If neither Bombardier-IS4Q-5300001 nor Bombardier-RD8/4-53-317 has been carried out, carry out DVI of Support Cleats <b>Compliance:</b> If RD8/4-53-328 is performed: 500 hrs IF RD8/4-53-328 is NOT performed: 200 hrs		EO-Q400-530034  Q400 5320000205	09MAR2003		<b>Remarks:</b> For pre-MTO 531075 aircraft or RD 8/4-53-317 and pre-MTO 531075 aircraft do the following: Perform inspections per TCA-CF-2003-28, item 3. For pre-MTO 531075 or RD 8/4-53-317 and post-MTO 531075 aircraft do the following: Perform inspection per Bombardier Recommended Alternate Means of Compliance (AMOC) dated 07JAN04, item (a). *****NOTE ***** Task "Q400 5320000205" (MOPS 5320000205) is made passive as EO-Q400-530027 (MTO531005) and EO-400-530031 (MTO531075) is fully performed on all Aircraft on 13DEC-2004 resp 28FEB-2005. /LP	
	Part 4	<b>Subject:</b> Terminating action for insp. <b>Compliance:</b> Latest 4000 hrs after 09JAN04	BOMBARDIER-IS4Q-5300001 BOMBARDIER-SB84-53-32 BOMBARDIER-SB84-53-32	EO-Q400-530027 EO-Q400-530031 EO-Q400-530035	09MAR2003 22JUL2004 N/A		<b>Remarks:</b> 531005A; Bombardier-IS4Q-5300001 531075A; Reinforcement with Angles Cleats and Stiffener 531104A; check records to determine if pre- or post-SB84-53-32 RevA has been done. If not perf. Eddy Current Insp per SB84-53-32 Rev A	
			<b>Subject:</b> Fuel and hydraulic tubes chafing <b>Compliance:</b> Part 1 latest 500 hrs after EFFDATE. EFFDATE is 2004-05-28 latest 4000 hrs after EFFDATE. EFFDATE is 2004-05-28					<b>Related AD:</b> FAA-2005-18-17
		Part 1	<b>Subject:</b> Install Bombardier Modsum 4-113438 (modified fairlead plate assemblies). <b>Compliance:</b> 500 hrs after Eff.date	BOMBARDIER-SYD-84-28-002 BOMBARDIER-SYD-84-29-006	EO-Q400-280004 EO-Q400-290009	24JAN2003 24JAN2003		<b>Applicability:</b> Aircraft Pre-SYD 84-28-002, Issue 1 and SYD 84 29 006, Issue 1. Not effective as TO 280306 and 290310 already was fully performed before effective date of AD.
TCA-CF-2004-11 13AUG2004	Part 2	<b>Subject:</b> Install Bombardier Modsum 4-113438 (modified fairlead plate assemblies). <b>Compliance:</b> 4,000 hrs after Eff.date	BOMBARDIER-SB84-54-09	EO-Q400-540014	19JUL2004		<b>Applicability:</b> Aircraft Post-SYD 84-28-002, Issue 1 and SYD 84 29 006, Issue 1 (TO 280306 resp 290310) <b>Related AD:</b> SLV-2004-233 FAA-2005-11-11	
		<b>Subject:</b> Special inspection and modification of flight control outboard flap front fittings at flap track NO 4 and NO 5 <b>Compliance:</b> Inspection within 400 HRS followed by repetitive inspection interval of 800 HRS. Modification within 4000 HRS. *All calc. after 2004-08-13						
A		<b>Subject:</b> Carry out an inspection of the flap track Number 4 front fittings on both the left and right outboard flap assemblies (Part 1 of the Bombardier Alert Service Bulletin (ASB) A84-57-06, Revision B, dated 9 March 2004, or later revision. Prior incorporation of RD8/4-57-228 in RD8/4-57-180 or RD8/4-57-226 satisfies the requirements of paragraph A. Insp. performed in accordance with previous issues of ASB A84	BOMBARDIER-AOM-109 BOMBARDIER-RD8/4-57-226 BOMBARDIER-RD8/4-57-228	EO-Q400-570009	13FEB2004		<b>Applicability:</b> All Paragraphs, DHC-8, Models 400, 401 and 402, Serial Numbers 4001, and 4003 through 4093. <b>Remarks:</b> If any fitting lug is found to be damaged due to fouling with a flap track or any fitting is found to be loose or any blind fastener is found to be non-conforming, prior to further flight, carry out repair in accordance with respectively paragraph of the above-noted Bombardier ASB.	



**Airworthiness Directives  
Compliance Status  
Airframe / Appliance / Engine / Propeller / APU**

**LN-RDK**  
Model: Q400  
TT A/C: 10457 H  
TC A/C: 12914 C  
Date from:

Mfg Date: 07OCT2000  
MSN: 4025

AD-Number Effective Date	Para & Sub	Subject / Compliance	Method of Compliance		Accompl. Status		Additional Information
			External Ref	Action Ref	Completed	Next Due	
B		57 06 satisfy the requirements of paragraph A. <b>Compliance:</b> Within 400 hrs after eff.date <b>Subject:</b> At any flap track Number 4 front fitting location WHERE RD8/4-57-173, RD8/4 57 180 or RD8/4-57-226 HAS NOT BEEN incorporated, repeat the inspection of Paragraphs A <b>Compliance:</b> at intervals not to exceed 800 hrs	BOMBARDIER-AOM-109 BOMBARDIER-RD8/4-57-226 BOMBARDIER-RD8/4-57-228	EO-Q400-570009	13FEB2004		
C		<b>Subject:</b> Carry out an inspection of the flap track Number 5 front fittings on both the left and right outboard flap assemblies iaw Part II of the Bombardier ASB A84-57-06, Revision B, dated 9 March 2004, or later revisions. At any flap track Number 5 front fitting location, prior incorporation of Bombardier ModSum IS4Q5750002 satisfies the requirements of paragraph C Inspections performed in accordance with previous issues of ASB A84-57-06 satisfy the requirements of paragraph C <b>Compliance:</b> Within 400 hours air time after eff.date	BOMBARDIER-AOM-108  BOMBARDIER-IS4Q-5750002	EO-Q400-570008  Q400 2750000004	13FEB2004		<b>Remarks:</b> if any fitting is found to be loose or if the gap between any fitting and the front spar web exceeds 0.002 inches or any blind fastener is found to be non-conforming, prior to further flight, carry out repair in accordance with the applicable paragraph Bombardier ASB.
D		<b>Subject:</b> At any flap track Number 5 front fitting location WHERE Bombardier ModSum IS4Q5750002 HAS NOT BEEN incorporated, repeat the inspection of Paragraphs C <b>Compliance:</b> At intervals not to exceed 800 hrs	BOMBARDIER-AOM-108 BOMBARDIER-IS4Q-5750002	EO-Q400-570008	13FEB2004		
E.1		<b>Subject:</b> Modify the attachment of the flap track Number 4 front fittings on both LH and RH Outboard Flap Assemblies. iaw Bombardier RD8/4-57-226, Issue 1, or later <b>Compliance:</b> Within 4,000 hours air time after eff.date	BOMBARDIER-RD8/4-57-226 BOMBARDIER-RD8/4-57-228 BOMBARDIER-SB84-57-06	Q400 2750000003 EO-Q400-570011	27FEB2004		<b>Remarks:</b> Terminating action for Part B <b>AMOC:</b> Aircraft that have already incorporated RD 8/4-57-173 or RD 8/4 57 180 at flap track Number 4 fitting location, do not require the incorporation of RD 8/4-57-226 at those fitting locations.
E.2		<b>Subject:</b> Modify the attachment of the flap track Number 5 front fittings on both LH and RH Outboard Flap Assemblies iaw Bombardier IS4Q5750002 <b>Compliance:</b> Within 4,000 hours air time after eff.date	BOMBARDIER-AOM-108 BOMBARDIER-IS4Q-5750002 BOMBARDIER-RD8/4-57-220 BOMBARDIER-SB84-57-06	EO-Q400-570010	22JUL2004		<b>Remarks:</b> Terminating action for Part D
TCA-CF-2005-07 08APR2005		<b>Subject:</b> Horizontal Stabilizer Attachment Fittings Bolt Torque Check, Shim Inspection and Modification <b>Compliance:</b> Part A: Within 4000 hrs after effectivity date EFFDATE= 2005-04-08 Part B: Within 8000 hrs after effectivity date EFFDATE= 2005-04-08					<b>Related AD:</b> SLV-2005-146 FAA-2005-26-05



**Airworthiness Directives  
Compliance Status**

**LN-RDK**  
Model: Q400  
TT A/C: 10457 H  
TC A/C: 12914 C

Mfg Date: 07OCT2000

MSN: 4025

**Airframe / Compliance / Engine / Propeller / APU**

Date from:

AD-Number Effective Date	Para & Sub	Subject / Compliance	Method of Compliance		Accompl. Status		Additional Information
			External Ref	Action Ref	Completed	Next Due	
TCA-CF-2005-08R1 27APR2005	A.1.	<b>Subject:</b> Within 4000 hours air time after the effective date of this directive, carry out an inspection of the laminated shims at the horizontal stabilizer to verify stabilizer forward attachment fittings and perform a breakaway torque check of the six attachment bolts at the front spar, mid-spar and rear spar attachment fittings, in acc. with Part A of Bombardier SB84-55-02, Rev. A, dated 12 Jan 2005, or later rev. <b>Compliance:</b> 4000 hrs after Eff. Date	BOMBARDIER-SB84-55-02	EO-Q400-550002	22.JUL.2004		<b>Remarks:</b> Notes to the AD paragraph, Note 1 Prior accomplishment of the actions required by paragraphs A.1 to A.3 of this directive in accordance with the original issue of Bombardier SB 84-55-02 satisfy the requirements of those paragraphs. Note 2 Prior incorporation of Bombardier Repair Drawings RD8/4-55-083, RD8/4-55-084, RD8/4-55-089, RD8/4-55-090, RD8/4-55-093, RD8/4-55-094, RD8/4-55-106, RD8/4-55-110 or RD8/4-55-138 satisfy the requirements of paragraph A.1 to A.3 of this directive.
	A.2/3.	<b>Subject:</b> 2. If any laminated shim is cracked, damaged or extruded from the horizontal stabilizer to the vertical stabilizer forward attachment fitting interface, prior to further flight, replace acc the mentioned Bombardier SB. 3. If any of the six attachment bolt breakaway torque value is outside the range specified in the above-mentioned Bombardier SB, prior to further flight, replace acc the mentioned Bombardier SB. <b>Compliance:</b> If required					
	B.1	<b>Subject:</b> If not already accomplished as required in paragraph A.2 of this directive, within 8000 hours air time after the effective date of this directive, replace the laminated shims at both left and right of the horizontal stabilizer to vertical stabilizer forward attachment fittings with solid shims. Part B of the Accomplishment Instructions of Bombardier SB 84-55-02, Revision A, dated 12 January 2005, or later rev. <b>Compliance:</b> 8000 hrs after Eff. Date	BOMBARDIER-SB84-55-02	EO-Q400-550002	22.JUL.2004		
	Note	<b>Subject:</b> Corrosion of Fuel Access Panel Attachment Anchor Nut. Inspection, sealing and terminating action <b>Compliance:</b> Part A: within 6 months after EFFDATE; OR Part B: within 6 months after EFFDATE; OR Part C: within 9 months after EFFDATE NOTE: No change in effectivity or compliance compared to original issue					<b>Related AD:</b> SLV-2005-363 FAA-2006-07-16 <b>AD Supersedes:</b> TCA-CF-2005-08
	Part A, para. a	<b>Subject:</b> Inspect all domed anchor nuts at all centre wing upper fuel access panel attachment locations in the wet bay area for signs of corrosion or perforation and replace all perforated or corroded anchor nuts with new anchor nuts of the same part number prior to further flight. Bombardier SB84-57-11, dated 25 February 2005, or later, provides approved	BOMBARDIER-SB84-57-11	EO-Q400-570015	N/A		<b>Remarks:</b> Part A and Part B is alternative initial action to be followed by the Terminating action law Part C <b>Applicability:</b> MSN 4001, 4003 thru 4115, unless SB Bombardier-SB84-57-12 / MTO 570706 or the Terminating Action (SB Bombardier-SB84-57-10 / MTO 570704) initially is done. <b>Remarks:</b> Para. b.; Within 24 months after accomplishing the requirements of Part A, paragraph a, replace all domed anchor nuts at all centre wing upper fuel access panel attachment locations in the



**Airworthiness Directives  
Compliance Status**

**LN-RDK**  
Model: Q400  
TT A/C: 10457 H  
TC A/C: 12914 C  
Date from:

Mfg Date: 07OCT2000  
MSN: 4025

**Airframe / Appliance / Engine / Propeller / APU**

AD-Number Effective Date	Para & Sub	Subject / Compliance Instructions. Compliance: 6 months from EFF.Date Subject: Inspect all domed anchor nuts at all centre wing upper fuel access panel attachment locations in the wet bay area for perforation. Replace all perforated anchor nuts with new anchor nuts of the same part number and install pre-cured sealant domes over all anchor nut domes. Bombardier SB84-57-12, dated 11 March 2005, or later, provides approved instructions. Compliance: 6 months from EFF.Date Subject: Replace all domed anchor nuts at all centre wing upper fuel access panel attachment locations in the wet bay area with corrosion resistant steel anchor nuts in accordance with Bombardier SB84-57-10 Revision A, dated 14 March 2005, or later revisions. Compliance: If done as stand-alone 9 months from EFFDATE if Part A is done; 12 months after it's performance date. If Part B is done; 24 months after it's performance date.	Method of Compliance		Accompl. Status		Additional Information
			External Ref	Action Ref	Completed	Next Due	
TCA-CF-2005-14R1 05JUN2006	Part B, para. a  Part C, para a.		EO-Q400-570016  EO-Q400-570014	BOMBARDIER-SB84-57-12  BOMBARDIER-SB84-57-10	07JUL2005  OPEN		wet bay area with corrosion resistant steel anchor nuts in accordance with Part C of this directive.  <b>Applicability:</b> MSN 4001, 4003 thru 4115, unless SB Bombardier-SB84-57-11 / MTO 570705 or the Terminating Action (SB Bombardier-SB84-57-10 / MTO 570704) initially is done. <b>Remarks:</b> Para. b.; Within 48 months after accomplishing the requirements of Part B, paragraph a, replace all domed anchor nuts at all centre wing upper fuel access panel attachment locations in the wet bay area with corrosion resistant steel anchor nuts in accordance with Part C of this directive. <b>Remarks:</b> TO Data to be updated individually on each aircraft, if Planned Date exceeds 27JAN-2006, i.e. Part A or B is done.
		<b>Subject:</b> Special inspection of fire extinguishing system electrical connectors at fire bottles, and installation of lanyard law SB84-26-07A or later <b>Compliance:</b> Part A: within 14 days after 19MAY-2005 (EFF.DATE) of original AD Part B: within 5000 Hrs after EFF.DATE of this revision NOTE: Part A performed iaw KTO 260399/260400	EO-Q400-260011R01  EO-Q400-260011R02	BOMBARDIER-SB84-26-07  BOMBARDIER-SB84-26-07	N/A  OPEN		<b>AD Supersedes:</b> TCA-CF-2005-14
	A 1 and 2	<b>Subject:</b> 1. Within 14 days after the effective date of this directive, carry out an inspection of the electrical connectors on the forward and aft baggage compartment, APU and engine nacelle fire bottles, in accordance with the Accomplishment Instructions of Bombardier Service Bulletin (SB) A84-26-06, dated 12 May 2005, or later revisions approved by the Chief, Continuing Airworthiness, Transport Canada. 2. Correct any deficiencies before the next flight. <b>Compliance:</b> Inspection within 14 days after effective date of this directive. Correction of deficiencies (if any) before the next flight.	EO-Q400-260008  EO-Q400-260009	BOMBARDIER-AOM-158  BOMBARDIER-SB84-26-06  BOMBARDIER-SB84-26-06	13MAY2005  25MAY2005		<b>Applicability:</b> MSN 4001 through 4107 <b>Remarks:</b> Note: The Bombardier Aircraft Maintenance Manual PSM 1-84-2 has been amended to clarify the instructions for connection of fire bottle electrical connectors. Temporary Revisions (TR) 26-017 through 26-027 were issued accordingly. KTO-260399 (Inspection and correction of deficiencies) started based on All Operators Message 158. KTO-260400 (Operationell check)
	B	<b>Subject:</b> Install/modify lanyards, mounts and clamps to the forward and aft baggage compartment, APU and engine nacelle fire extinguishing systems by incorporating Modsum 4-109941. Bombardier Service Bulletin 84-26-07, Revision A, dated 21 February 2006, or later revisions approved by the Chief,	EO-Q400-260011	BOMBARDIER-SB84-26-07	N/A		<b>Applicability:</b> MSN 4001 through 4107 <b>Remarks:</b> Previous incorporation of Modsum 4-109941, in accordance with the Accomplishment Instructions in the original issue of Bombardier Service Bulletin 84-26-07, dated 15 June 2005, meets the requirements of this part (Part B of this directive).



**Airworthiness Directives  
Compliance Status  
Airframe / Appliance / Engine / Propeller / APU**

**LN-RDK**  
Model: Q400  
TT A/C: 10457 H  
TC A/C: 12914 C  
Date from: MSN: 4025  
Mfg Date: 07OCT2000

AD-Number Effective Date	Para & Sub	Subject / Compliance	Method of Compliance		Accompl. Status		Additional Information	
			External Ref	Action Ref	Completed	Next Due		
TCA-CF-2005-15 17JUN2005		Continuing Airworthiness, Transport Canada, provides approved instructions for incorporating Modsum 4-108941. <b>Compliance:</b> Within 5000 hours air time after the effective date of this revision. <b>Subject:</b> Pitot static contamination <b>Compliance:</b> 2005-07-16 NOTE: MR 3411004/3411006 + 3412004/3412006 already done at 1000h/24m since 08Mar-2004. (MR 3411001/3412001 added of practical reasons)					Related AD: SLV-2005-207	
	A	<b>Subject:</b> Cleaning of Pitot Static Probe Drain Hole Initially, within 30 days after the effective date of this directive and thereafter at intervals not to exceed 70 hours air time, clean the drain hole of all the pitot static probes in accordance with Dash 8 Q400 Aircraft Maintenance Manual (AMM), PSM 1-84-2, Task 20-00-40-170-801 and as follows:						
A.1.		<b>Subject:</b> Con't from "A" a. Clean the drain holes in accordance with paragraph 4.B., Procedure 2, sub-paragraph (1) to (3) of the above noted AMM task. b. After cleaning, examine the drain hole for blockage in accordance with Paragraph 4.A., Procedure 1 of the above noted AMM task. c. If the drain hole of any pitot static probe is blocked, repeat the cleaning and examination procedure of Paragraph A.1.a and A.1.b of this directive on the affected pitot static probe. <b>Compliance:</b> 17JUL-2005	EO-Q400-340037		09JUN2005		<b>Applicability:</b> All Q400 <b>Remarks:</b> Prevoius the drains was cleaned with 1000 H Interval	
			Q400 L-CHECK		10453 FH	10503 FH		
			Q400 3411000004					
			Q400 3412000004					
			EO-Q400-340037 Q400 567 Q400 341100-201 Q400 341100-204 Q400 341201-201 Q400 341201-204		09JUN2005 10036 FH	10636 FH		<b>Applicability:</b> All Q400 <b>Remarks:</b> Previous the Pitot Lines was cleaned with 24 months interval MR 3411001/3412001 added as they are on same J/C as the 3411006/3412006
B	<b>Subject:</b> Cleaning of Pitot Lines Initially, within 30 days after the effective date of this directive and thereafter at intervals not to exceed 600 hours air time, clean the pitot lines in accordance with Dash 8 Q400 AMM, PSM 1-84-2, Task 34-11-00-170-801. <b>Compliance:</b> 17JUL-2005						<b>Remarks:</b> SAS statistic does not support the low AD time limits	
TCA-CF-2005-37 31OCT2005		<b>Subject:</b> Special Inspection and Rectification for Cracks In Outer Wing Fuel Access Panels 524AT (left wing) and 624AT (right wing) <b>Compliance:</b> PART A: Within 400H after 2005-10-31 PART B: Repetitive insp. each 1200H PART C: Terminating action within 6000H after initial inspection	BOMBARDIER- RD8/4-57-451 BOMBARDIER- SB84-57-13 BOMBARDIER- SB84-57-13 BOMBARDIER- SB84-57-13 BOMBARDIER- SB84-57-13	EO-Q400-570019R01	OPEN		Related AD: SLV-2005-449	
			EO-Q400-570020R01 EO-Q400-570020R02 EO-Q400-570020R03	OPEN OPEN OPEN	14876 FH			



**Airworthiness Directives  
Compliance Status  
Airframe / Appliance / Engine / Propeller / APU**

**LN-RDK**  
Model: Q400  
TT A/C: 10457 H  
TC A/C: 12914 C  
Date from:

Mfg Date: 07OCT2000  
MSN: 4025

AD-Number Effective Date	Para & Sub	Subject / Compliance	Method of Compliance		Accompl. Status		Additional Information
			External Ref	Action Ref	Completed	Next Due	
A.1		<b>Subject:</b> Within 400 hours air time after the effective date of this directive, carry out an ultrasonic inspection for cracks of the outer wing fuel access panels, P/N 85714230-001, on both left and right wing, in accordance with Accomplishment Instructions of Bombardier Service Bulletin 84-57-13, dated 17 August 2005, or later revisions approved by the Chief, Continuing Airworthiness, Transport Canada. <b>Compliance:</b> Within 400 hrs after 31OCT-05	SB84-57-13 BOMBARDIER-RD8/4-57-451	EO-Q400-570019	19JAN2006		<b>Applicability:</b> Applicable to all <b>Remarks:</b> INITIAL Inspection
A.2		<b>Subject:</b> If any access panel is cracked, perform one of the following prior to further flight: <b>Compliance:</b> All cracked panels must have A.2 (a) OR A.2(b) OR A.2(c) done prior to further flight					<b>Applicability:</b> All aircraft but only if panels are found cracked.
A.2(a)		<b>Subject:</b> Replace cracked panel with either panel, P/N 85714230-003 or 85714230-005.	BOMBARDIER-SB84-57-13	EO-Q400-570020	N/A		<b>Remarks:</b> Note this a terminating action for the repetitive inspection
A.2(b)		<b>Subject:</b> Incorporate temporary repair in accordance with Bombardier Repair Drawing, RD 8/4-57-451. Subsequently, replace the repaired panel within 1000 hours air time from time of incorporation of RD 8/4-57-451. <b>Compliance:</b> Note that the panel must be replaced within 1000 hrs	BOMBARDIER-RD8/4-57-451	EO-Q400-570019	19JAN2006		<b>Remarks:</b> A complaint card must be issued if a panel is repaired, this to control replacement after 1000 hrs.
A.2(c)		<b>Subject:</b> Replace the cracked panel with a new panel P/N 85714230-001. Ensure that the replacement panel has no crack, by carrying out an ultrasonic inspection for cracks in accordance with Accomplishment Instructions of the above-noted Bombardier Service Bulletin	BOMBARDIER-RD8/4-57-451	EO-Q400-570019	19JAN2006		<b>Remarks:</b> Note that this is NOT an terminating action. Inspection program must continue as per MR
A.3		<b>Subject:</b> If the inspection required in paragraph A.1 of this directive reveals no crack, or if a cracked access panel is replaced in accordance with paragraph A.2.(c) of this directive; prior to further flight, conduct an ultrasonic inspection of the outer wing fuel access panels, P/N 85714230-001, to determine the presence of a radius in the seal groove, in accordance with Accomplishment Instructions of the above-noted Bombardier Service Bulletin.	BOMBARDIER-RD8/4-57-451	EO-Q400-570019	19JAN2006		
B		<b>Subject:</b> Repeat Inspection for Cracks of Outer Wing Fuel Access Panels. <b>Compliance:</b> First repetitive inspection within 1200 hrs calculated from the time KTO 570746 (Initial inspection) is completed. Thereafter with	BOMBARDIER-RD8/4-57-451 BOMBARDIER-SB84-57-13	EO-Q400-570019 Q400 687	10036 FH	11236 FH	<b>Applicability:</b> All Fuel Access Panels with pre-MTO570747 status (i.e. PN 85714230-001) <b>Remarks:</b> Note that if a panel is repaired iaw Bombardier Repair Drawing, RD 8/4-57-451, the repaired panel must be replace within 1000 hours air





**Airworthiness Directives  
Compliance Status  
Airframe / Engine / Propeller / APU**

**LN-RDK**  
Model: Q400  
TT A/C: 10457 H  
TC A/C: 12914 C  
Date from:

Mfg Date: 07OCT2000  
MSN: 4025

AD-Number Effective Date	Para & Sub	Subject / Compliance	Method of Compliance		Accompl. Status		Additional Information
			External Ref	Action Ref	Complied	Next Due	
	B.1	1200 hrs intervals <b>Subject:</b> If no crack is found on P/N 85714230-001 outer wing fuel access panel, and a radius is present in the seal groove at all locations, carry out repetitive detailed visual inspections of the external surface of the panel for any sign of cracking, in accordance with accomplishment instructions of the above-noted Bombardier Service Bulletin, at intervals not exceeding 1200 hours air time. <b>Compliance:</b> All panels must have DVI inspection law SB84-57-13 Notice that NDT is not required	Q400 5720009909 Q400 687	Q400 687	10036 FH	11236 FH	time from time of incorporation of RD 8/4-57-451.
	B.2	<b>Subject:</b> If no crack is found on P/N 85714230-001 outer wing fuel access panel, and a radius is not present at any of the locations noted for inspection, repeat the ultrasonic inspection for cracks in accordance with paragraph A.1 and A.2 of this directive, at intervals not exceeding 1200 hours air time. <b>Compliance:</b> All panels must have both DVI and NDT inspection law SB84-57-13	Q400 687	Q400 687	10036 FH	11236 FH	
	C	<b>Subject:</b> Terminating Action.					
	C.1	<b>Subject:</b> Within 6000 hours air time after the initial inspection required by this directive, replace the left and right outer wing fuel access panels, P/N 85714230-001, with either P/N 85714230-003 or 85714230-005 panel. <b>Compliance:</b> Within 6,000 hrs from compliance of KTO 570746	BOMBARDIER- RD8/4-57-451 BOMBARDIER- SB84-57-13 BOMBARDIER- SB84-57-13	EO-Q400-570019	19JAN2006 N/A		<b>Applicability:</b> All
TCA-CF-2005-39 22DEC2005		<b>Subject:</b> Check for Incorrect Rivets Installed at Control Column Torque Tube <b>Compliance:</b> Within 5500 flthrs after Effective Date, that is 2005-12-22	BOMBARDIER- SB84-27-24 BOMBARDIER- SB84-27-24	EO-Q400-270044 EO-Q400-270044R01	N/A OPEN	14280 FH	<b>Related AD:</b> SLV-2005-485
TCA-CF-2006-05 28APR2006		<b>Subject:</b> Breake Control Cable Fouling on Camlock Fastener, Special Inspection Inspection for damage and filament box provisioning <b>Compliance:</b> inspect within 12 months law SB part 3.B(1) and thereafter, within 24months after initial inspection, rework law SB part 3.B (5) NOTE: It has been decided to do the complete work in one step					<b>Related AD:</b> SLV-2006-115
	(a)	<b>Subject:</b> Perform a visual inspection of the outboard brake control cable, P/N 83200551-001, for fouling/damage. <b>Compliance:</b> Within 12 months of the effective date of this directive.	BOMBARDIER- SB84-53-37	EO-Q400-530038	OPEN	27APR2007	<b>Applicability:</b> All Q400



**Airworthiness Directives  
Compliance Status**

**LN-RDK**  
Model: Q400  
TT A/C: 10457 H  
TC A/C: 12914 C  
Date from:

Mfg Date: 07OCT2000  
MSN: 4025

**Airframe / Appliance / Engine / Propeller / APU**

AD-Number Effective Date	Para & Sub	Subject / Compliance	Method of Compliance		Accompl. Status		Additional Information
			External Ref	Action Ref	Completed	Next Due	
	(b)	<b>Subject:</b> If damage to any cable is found, replace the brake control cable and rework the cable cover and, if applicable, manufacture/install the offset plate assembly. <b>Compliance:</b> If fault is found: Complete the cable replacement and modifications before further flight.					Applicability: All Q400
	(c)	<b>Subject:</b> If no damage to the cable assembly is found during the visual inspection, rework the cable cover and, if applicable, manufacture/install the offset plate assembly, within 24 months of the date of the inspection. <b>Compliance:</b> Formally within 24 months after initial inspection law (a).	BOMBARDIER-SB884-53-37	EO-Q400-530038	OPEN	27APR2007	Applicability: All Q400 <b>Remarks:</b> It has been decided to do the complete inspection and modification at once
<b>APPLIANCE</b>							
FAA-2001-15-17/Q400 20AUG2001		<b>Subject:</b> ROCKWELL COLLINS - Modify the altitude encoder inputs of the CTL-92 transponder control panels. P/N 622-6523-204, -205, -206, -207 & -208 <b>Compliance:</b> See AD					<b>Action Taken:</b> NOT APPLIC <b>Action Note:</b> Collins CTL-92 not used in SAS Q400
FAA-2002-06-06/Q400 03MAY2002		<b>Subject:</b> ROCKWELL COLLINS - Prevent erroneous altitude resolutions from causing a reduction in intended TCAS change 7 minimum separation margins <b>Compliance:</b> See AD					<b>Action Taken:</b> NOT APPLIC <b>Action Note:</b> Collins TDR-94 and TDR-94D Mode S transponders not used in SAS Q400
FAA-2002-21-01/Q400 27NOV2002		<b>Subject:</b> REPLACE WIRING ON TEMPERATURE LIMITER <b>Compliance:</b> AT NEXT REPAIR, MAINTENANCE OR DESCALING (REMOVAL), NEXT A/C DOWNTIME THAT ALLOWS FOR WIRING-REPL. OR LATEST WITHIN 1 YEAR FROM EFFDATE	BRITAXSELL-E33-4-007SB BRITAXSELL-E33-4-007SB	EO-COMP-380001 EO-Q400-380002	62203-001-007 00-05-0009:22DEC2000 26DEC2000		<b>Related AD:</b> LBA-2000-379/Q400 LBA-2000-379/R2/Q400 <b>AD Supersedes:</b> FAA-2001-10-13/Q400
CAA-AD-003-09-2000 01NOV2000	(a thru c)	<b>Subject:</b> Propeller electronic controller unit removal <b>Compliance:</b> See AD Paragraphs					
		<b>Subject:</b> Identify Original S/N to be Batch 1 or Batch 2. Remove as per "Compliance" <b>Compliance:</b> All the units identified in Batch 1 must be removed from the aircraft in not more than one calendar month from receipt of this service bulletin. If two units from Batch 1 are installed on a single aircraft, one of the units must be removed in not more than one calendar week from receipt of this service bulletin. All the units identified in Batch 2 must be removed from the aircraft in not more than one calendar year from receipt of this service bulletin.	DOWTYROTOL-D8400-61-23	EO-Q400-610001		12OCT2000	



**Airworthiness Directives  
Compliance Status  
Airframe / Appliance / Engine / Propeller / APU**

**LN-RDK**  
Model: Q400  
TT A/C: 10457 H  
TC A/C: 12914 C  
Mfg Date: 07OCT2000  
MSN: 4025  
Date from:

AD-Number Effective Date	Para & Sub	Subject / Compliance	Method of Compliance		Accompl. Status		Additional Information
			External Ref	Action Ref	Complied	Next Due	
LBA-2000-379/R2/Q400 11JAN2001	(a)	<p><b>Subject:</b> Modify Unit</p> <p><b>Compliance:</b> Units identified in Batches 1 and 2 may be installed again when this service bulletin (Mod. Strike 2 standard) has been included.</p> <p><b>Subject:</b> BRITAX SELL - Inspection/ replacement of remote Water Boiler/ Coffee maker</p> <p><b>Compliance:</b> 1) Inspect within 50 FH after effdate of AD 2) Replace effected wires at next C-check</p>	DOWTYROTOL-D8400-61-23	EO-COMP-610001	N/A		Related AD: RLD-BLA-2000-139;R2, SLV-2000-336-436;R1 AD Supersedes: LBA-2000-379/Q400
1		<p><b>Subject:</b> Inspection of terminal contact pins for signs of overheating and electrical arcing.</p> <p><b>Compliance:</b> Within the next 50 FH from issue date of KTO (2000-12-15)</p>	BRITAXSELL-E33-4-007SB	EO-Q400-380002	26DEC2000		
2		<p><b>Subject:</b> Replacement of wires.</p> <p><b>Compliance:</b> First shop visit but latest 31DEC2001.</p>	BRITAXSELL-E33-4-007SB	EO-COMP-380001	62203-001-007 00-05-0009;22DEC2000		
SLV-2003-066-480/Q400 11FEB2003		<p><b>Subject:</b> HONEYWELL - Model MST 67A mode transmitter series. Replacement to eliminate corruption in the PI field in mode S format DF=11</p> <p><b>Compliance:</b> 31mar03</p> <p>NOTE: Exemption to 30APR2003. Ref STK-2003-088A-1072</p>	HONEYWELL-MST-67A-SW2	EO-COMP-340001	N/A		Related AD: RLD-BLA-2003-036, LTN-2003-029 CAA-001-01-2003
TCA-CF-2006-08 31MAY2006		<p><b>Subject:</b> Amendment of AFM, PSM 1-84-1A, by inserting Temp. Admendment No 13 and Crew Advice, Regarding Hyd. System Pwr Transfer Unit Overspeed</p> <p><b>Compliance:</b> NOTE: The action is purely on Operational Matters; Amendment to AFM and Information to the Crew</p>		EO-Q400-340032	29MAR2003		
1		<p><b>Subject:</b> Amend all AFM, PSM 1-84-1A, by inserting Temporary Amendment (TA) No. 13, dated 14 July 2005, or later approved changes to this AFM temporary amendment.</p> <p><b>Compliance:</b> 14 JUN-2006</p>		EO-Q400-290023	01JUN2006		Applicability: All AFM controlled by SAS
2		<p><b>Subject:</b> Advise all flight crew of the changes introduced by the AFM temporary amendment.</p> <p><b>Compliance:</b> 14 JUN-2006</p>		EO-Q400-290023	01JUN2006		Applicability: All flightcrew qualified for Q400 duty
3		<p><b>Subject:</b> Amend all SAS OMB/Q400 accordingly</p> <p><b>Compliance:</b> 14 JUN-2006</p>		EO-Q400-290023	01JUN2006		Applicability: All SAS OMB/Q400
3.0		<p><b>Subject:</b> Amend all SAS Q400 QRH accordingly.</p> <p><b>Compliance:</b> 14 June 2006</p>		EO-Q400-290023	01JUN2006		Applicability: All Q400 QRH's
3.1		<p><b>Subject:</b> Check of incorporation of revision to QRH Page 12.3 ref KTO 290367A</p> <p><b>Compliance:</b> Latest 14 June 2006</p>		EO-Q400-290024	02JUN2006		Applicability: All Q400's



**Airworthiness Directives  
Compliance Status  
Airframe / Engine / Propeller / APU**

**LN-RDK**  
Model: Q400  
TT A/C: 10457 H  
TC A/C: 12914 C  
Date from:

Mfg Date: 07OCT2000  
MSN: 4025

AD-Number Effective Date	Para & Sub	Subject / Compliance	Method of Compliance		Accompl. Status	Additional Information
			External Ref	Action Ref		
CAA-AD-007-05-2000 10AUG2000	4	<p><b>Subject:</b> In a signed IOC or Letter forwarded to CPHMR-Z/Niels-Anders Nielsen, confirm that paragraph 1, 2 and 3 is fully performed. This must be accompanied with documents showing the exact wording for paragraph 2 and 3. (ref a STK Audit)</p> <p><b>Compliance:</b> Highly Desirable; No later than 12 JUNE-2006 (to allow time for signing off this KTO)</p>		EO-Q400-290023	01 JUN2006	Remarks: Note that the letter and accompanied documents may be forwarded via E-mail provided they are scanned documents showing a signature.
	5	<p><b>Subject:</b> After receipt of the signed letter, CPHMR will inform CPHMT-P that the KTO shall be signed off as fully completed.</p> <p><b>Compliance:</b> 14 JUN-2006</p>		EO-Q400-290023	01 JUN2006	Applicability: All Q400
<p><b>ENGINES:</b> P/MSN ORG: 3121627-01 / PCE-FA0136 (LH) P/MSN ORG: 3121627-01 / PCE-FA0228 (RH)</p>						
TCA-CF-2006-06 08MAY2006		<p><b>Subject:</b> Propeller - High crosswind operation life limitation</p> <p><b>Compliance:</b> Mandatory if A/C is operated in X-wind as described</p> <p>NOTE: Revision of AOM OM-B. 1.8.6.6 is based upon information given in SB DOWTYROTOL-D8400-61-21</p>				
	Corrective Action	<p><b>Subject:</b> Engine Exhaust Shroud V-band Couplings, Inspection for Mfg Date (earlier than Aug-02), and possible replacement</p> <p><b>Compliance:</b> Within 5,000 flhrs after Eff.Date</p> <p><b>Subject:</b> Carry out an inspection and replacement (as required) of the V-band clamps to ensure a proper gap, in accordance with Bombardier SB 84-78-01, Revision A, dated 15 September 2005, or its later revisions approved by the Chief, Continuing Airworthiness, Aircraft Certification Branch, Transport Canada.</p> <p><b>Compliance:</b> Within 5000 flight hours after the effective date of this directive.</p>	BOMBARDIER-SB84-78-01	EO-Q400-780001R01	OPEN	14481 FH
FAA-2004-24-03/Q400 03JAN2005		<p><b>Subject:</b> Fuel filter by pass button, installation of a bracket to prevent protrusion and possible fuel leakage</p> <p><b>Compliance:</b> 500 Hrs Time-In-Service or within 6 months from effective date 2005-01-03</p>				
	(f)	<p><b>Subject:</b> Install a bracket onto the fuel filter housing assembly on APU Model T-62T-46C12. Use 2.A through 2.D of the Accomplishment Instructions of Hamilton Sundstrand Alert Service Bulletin (ASB) No. ASB-4503067-49-9, dated December 2, 2003, to install the bracket.</p>	HAM.SUND-SB4503067-49-9	EO-COMP-490001	4503067A SP-E984509:18FEB2004	APU  <b>Applicability:</b> All APU <b>Remarks:</b> Previous credit is allowed for brackets installed using Hamilton Sundstrand ASB No. ASB-4503067-49-9, dated December 2, 2003, before the effective date of this AD.



**Airworthiness Directives  
Compliance Status  
Airframe / Appliance / Engine / Propeller / APU**

**LN-RDK** Q400  
**Model:** Q400  
**TT A/C:** 10457 H  
**TC A/C:** 12914 C  
**Mfg Date:** 07OCT2000  
**MSN:** 4025

AD-Number Effective Date	Para & Sub	Subject / Compliance	Method of Compliance		Accompl. Status		Additional Information
			External Ref	Action Ref	Completed	Next Due	
SLV-AIC-A-12/02/Q400 05DEC2002		<p><b>Compliance:</b> Within 500 hours time-in-service or 6 months after the effective date of this AD, whichever occurs earlier, unless the actions have already been done.</p> <p><b>Subject:</b> Carriage &amp; Operation of SSR Made S Airborne Equipment in European Airspace, Transitional Arrangements. Namely Elementary Surveillance SSR</p> <p><b>Compliance:</b> 2007-03-31 law latest from Eurocontrol. For exemption see AIC.A.13/04</p> <p><b>NOTE:</b> This AIC regulates the danish airspace, for other countries see resp regulations</p>	BOMBARDIER-SB84-34-52 BOMBARDIER-SB84-34-54 BOMBARDIER-IS4Q3450000 BOMBARDIER-SB84-34-53	EO-Q400-340035  EO-Q400-340036	22JUL2004  05JUN2005		<b>ARQ</b>
SLV-2002-114-125/R1 09APR2002		<p><b>Subject:</b> DEMANDED STATUS OF AD-NOTES AT TIME OF APPLYING/RENEWAL OF DANISH AIRWORTHINESS CERTIFICATE</p> <p><b>Compliance:</b> AT TIME OF APPLYING/RENEWAL OF DANISH AIRWORTHINESS CERTIFICATE</p>		EO-Q400-150002	29JUL2002		<b>AD Supersedes:</b> SLV-2002-114-125
TCA-CF-2004-19 2DOCT2004		<p><b>Subject:</b> ALI-37; Incorp. Rev. Structural Inspection Tasks. ALI-28; Incorp. Rev Safe Lifelimits for Orifice Support Tube, Upper Bearing, Piston Plug</p> <p><b>Compliance:</b> 2004-10-20</p> <p><b>NOTE:</b> KN affected 844259, 844260, 844261</p>		EO-Q400-710015 Q400 712001F102 Q400 712003F102	26OCT2004		<b>Related AD:</b> SLV-2004-357, FAA-2005-12-15
	1.	<p><b>Subject:</b> Incorporating the revised structural inspection tasks, 712001F102 and 712003F102 respectively as introduced by Temporary Revision, ALI-37 of Airworthiness Limitations Items (ALI) of the DHC-8-400 Maintenance Requirements Manual, PSM 1-84-7</p> <p><b>Compliance:</b> Within 30 days after the effective date of this directive</p>					<b>Applicability:</b> DHC-8 Aircraft, Models 400, 401 and 402, serial numbers 4001, and 4003 through 4094. <b>Remarks:</b> KTO-710422 to describe and ensure compliance
	2.	<p><b>Subject:</b> Incorporating the revised safe life limits for the Orifice Support Tube, P/N 46117-1, Upper Bearing, P/N 46114-1, and Piston Plug, P/N 46137-1, as introduced by Temporary Revision, ALI-28 of Airworthiness Limitations Items (ALI) of the DHC-8-400 Maintenance Requirements Manual, PSM 1-84-7</p> <p><b>Compliance:</b> Within 30 days after the effective date of this directive</p>		EO-Q400-710015	26OCT2004		<b>Applicability:</b> DHC-8 Aircraft, Models 400, 401 and 402, serial numbers 4001, and 4003 through 4094. <b>Remarks:</b> KTO-710422 to describe and ensure compliance. P/N 46117-1 (MOPS P601 "CBL set to 13311" 06OCT2004) P/N 46114-1 (MOPS P601 "CBL set to 22032" 06OCT2004) P/N 46137-1 (MOPS P601 "CBL set to 22032" 06OCT2004) Demanded interval 14500 C (P/N 46117-1) and 24000 C (P/N 46114-1 and 46137-1) multiplied with HGW factor 0.918 due to ModSum 4-308807. Referred "ALI-28" has been replaced by later "ALI"s.
TCA-CF-2006-10 15JUN2006		<p><b>Subject:</b> Airworthiness limitation Items, Mandatory Incorporation of ALI-53 and ALI-54</p>					
	1	<p><b>Subject:</b> Incorporating the additional structural inspection tasks, 532065F101, 532065F102.</p>		EO-Q400-050001	19JUN2006		<b>Applicability:</b> Maintenance Requirement Affected in MOPS and in AuRA. Incorporation signed off on each



**Airworthiness Directives  
Compliance Status  
Airframe / Appliance / Engine / Propeller / APU**

**LN-RDK**  
Model: Q400  
TT A/C: 10457 H  
TC A/C: 12914 C  
Date from:

Mfg Date: 07OCT2000  
MSN: 4025

AD-Number	Effective Date	Para & Sub	Subject / Compliance	Method of Compliance		Accompl. Status		Additional Information
				External Ref	Action Ref	Completed	Next Due	
			532066F101, 532066F102 for Post Modsum 4-113458, 532066F103, 532067F101, 532067F102, 532067F103, 532068F101, 532068F102, 532069F101, 532069F102, 532069F103, 532070F101, 532070F102, 532071F101, 532072F101, 532072F102, 532073F101 and 532073F102 respectively as introduced by Temporary Revision, ALI-53 of Airworthiness Limitations Items (ALI) of the DHC-8-400 Maintenance Re-requirements Manual, PSM 1-84-7 <b>Compliance:</b> Latest 12AUG-2006					Individual Q400
2			<b>Subject:</b> Incorporating the revised structural task 521003F101 Revision, ALI -54 of Airworthiness Limitations Items Maintenance Requirements Manual, PSM 1-84-7. <b>Compliance:</b> Latest 12AUG-2006		EO-Q400-050001	19JUN2006		<b>Applicability:</b> Maintenance Requirement Affected in MOPS and in AuRA. Incorporation signed off on each individual Q400
3			<b>Subject:</b> When incorporation is done, MR-Z to inform PSD/Q400, that in turn will initiate that this TO will be signed off in the Maintenance System MOPS and AuRA. <b>Compliance:</b> Latest 12AUG-2006					<b>Remarks:</b> When this paragraph has been done, it is indirectly indicated with a sign off of para. 1 and 2.

Created 02NOV2006

Last page of list



**Airworthiness Directives  
Compliance Status  
Airframe / Appliance / Engines / APU**

**LN-RDK**

Model: Q400

Mfg Date:

TT A/C: 10596 H

TC A/C: 13070 C

MSN: 4025

AD-Number		Subject / Compliance	Method of Compliance		Accompl. Status		Additional Information
Effective Date	Para & Sub		External Ref	Action Ref	Complied	Next Due	
EASA-2006-0334/Q400		<b>Subject:</b> COMMUNICATIONS - THALES COMMUNICATIONS VHF DATA RADIO - MODIFICATION <b>Compliance:</b> Valid for SAS Q400 fleet without amendment 3 (SB EVR716-23-015)					
14NOV2006							

The preview was created 23NOV2006

**Back**

**Refresh**

**Print**

**Info**

# LN-RDK 11 December 2006

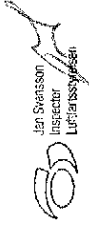

Ian Swanson  
Inspector  
Lubrication

**AMBA Client PRODUCTION**  
 File Edit Administration Material Management Maintenance Engineering Inquiries/Reporting Help  
**Maintenance Planning Review/SW40/TM\_LIS001**

Unit Code: (AU) LN-RDK Prov SC: (AD) G400 Stock Point: (AB) G4025 Work Center: (AI) Pending  
 Tail Number: LN-RDK Part Number: G400 Serial: LDR Hrs Ref: Show All Interval Types  
 Budget: 0.00 ECD: Status: Show All Interval Types

Scheduled | Non-Routine | Rev Part

Task Code	Description	Interval	When Due	Est Lbr	Remain	Est Lbr	Group	W	Work Pkg ID	Mandatory	MS Proj	Status
G400 601	MIG CLEANING, INSPECTION AND LUBRICATION	FLT HRS	2006-12-15	39.21	12	6	X	20061200602	X			Active
G400 601	ENGINE OIL CHECK	FLT HRS	2006-12-15	33.64	1	1						Pending
G400 403-REP	REMOVE STANDBY BATTERY FOR RESTORATION-R	FLT HRS	2006-12-16	48.12	1	1	X	20061102287				Active
DEF0003730M	INSP CARGO DOOR FITTING	FLT HRS	2006-12-16	41.18								Pending
G400 L-CHECK	L-CHECK	FLT HRS	2006-12-16	41.18	1.5	2						Pending
G400 518	REPORTING OF APJ HOURS AND CYCLES	DAYS	2006-12-18	7	0.5	1	X	20061102287				Active
G400 542N	FMS UPDATE	DAYS	2006-12-21	10	0.5	1	X	20061102287				Pending
G400 501	OPERATIONAL CHECK OF THE EMERGENCY LIGHT	FLT HRS	2006-12-23	86.63	0.5	1	X	20061102287				Active
G400 615	LH ENG REPL MAIN AND SCAVENGE OIL FILTER	FLT HRS	2006-12-25	119.27	6	4	X	20061102287				Active
G400 593	INSP / CLEAN OF PILOTS FULL FACE MASKS	DAYS	2006-12-27	15	1	1	X	20061102287				Active
G400 587	DVI CVR AND FDR PROTECTION SHIELD	DAYS	2006-12-27	16	1	1	X	20061102287				Active
G400 700	DVI THE YAW DAMPER ACTUATOR	FLT HRS	2006-12-30	153.44	4	4	X	20061200602				Active
G400 403-REP	REMOVE AUX BATTERY FOR RESTORATION-REP	FLT HRS	2006-12-30	154.05	1	1	X	20061200602				Active
G400 401-REP	REMOVE MAIN BATTERY FOR RESTORATION-REP	FLT HRS	2006-12-30	154.05	1	1	X	20061200602				Active
EC-G400-290021R02	HYDRAULIC POWER-INSTALLATION OF A NEW EN	DAYS	2006-12-31	20	7	8	X	20061000264				Scheduled
EC-G400-340041R01	UPDATE MK V EGRMS WITH TERRAIN DATABASE	DAYS	2006-12-31	20	1	1						Scheduled
EC-G400-520073	DOORS - AIRSTAIR DOOR - SPECIAL INSPECTI	DAYS	2007-01-01	21	12	10	X	20061000264				Pending
EC-G400-580007	GALLEY NO 1, POTABLE WATER, FILL AND OVE	DAYS	2007-01-01	21	36	72	X	20061000264				Scheduled
G400 645	DRAIN THE TAIL DISTRIBUTION DE-VALVES	FLT HRS	2007-01-01	174.74	0.5	2	X	20061200602				Active
G400 513	EXTERNAL CLEANING OF A/C	FLT HRS	2007-01-05	203.71	0.4	2						Pending
G400 583	FUC ELEVATOR CONTROL STICK PUSHER	FLT HRS	2007-01-11	254.05	1	1						Pending
G400 A2-CHECK	A2-CHECK G400 SAS COMMUTER	FLT HRS	2007-01-11	254.05	36	6						Pending
G400 508	OPC ATTITUDE AND HEADING REFERENCE SYS	FLT HRS	2007-01-12	261.56	1.5	2						Pending
G400 645	EDDY CURRENT OF AIRSTAIR DOOR HINGE	FLT HRS	2007-01-13	271.51	1.5	2						Pending
G400 686	SANITIZING OF PORTABLE WATER SYSTEM	DAYS	2007-01-14	277.27	2	2						Pending
G400 730852-RH	RH ENGINE - INSPECTION OF FUEL HEATER	FLT HRS	2007-01-14	34	4	5						Scheduled
EC-G400-610006	PROPELLER-PROPELLER ELECTRONIC CONTROLLE	DAYS	2007-01-14	35	0	0						Pending
EC-G400-610007	61-10 PROPELLER-HUB ACTUATOR AND BACKPLA	DAYS	2007-01-15	282.51	1.5	2	X	20061000264				Scheduled
G400 686	REPLACE FILTERS IN THE FD DISPLAYS	FLT HRS	2007-01-15	282.51	1.5	2						Pending

Task Code: G400 601 Recurrence: 3 MIG CLEANING, INSPECTION AND LUBRICATION  
 Planned Start Date: 2006-12-20  
 Tail Number: LN-RDK  
 El Part No/ Serial: G400

Select All | De-Select All

Request Inq. | Material Inq. | Upgrade Inq. | Location | Repair Parts | Upgrade Inq. | Detail

Done



## **Bilag 4**



## Bombardier Q400

### All Operator Message No. 236A

---

ATTN: Director/Manager of: Maintenance  
Engineering  
Quality Control  
Flight Operations  
Procurement/Spares

DATE: 11 September 2007

ATA: 3210 MODEL: Q400

SUBJECT: Update - In-service Incident – Right Main Landing Gear Collapse After Landing

REFERENCE: /A/ AOM 235, In-service Incident – Right Main Landing Gear Collapse After Landing

The following message is being sent to all Bombardier Q400 Operators and Bombardier Aerospace Field Service Representatives.

This message contains information requiring attention and/or action. Please ensure timely and appropriate distribution within maintenance and flight operations departments.

---

#### DISCUSSION:

This AOM is being re-issued to clarify compliance time and actions requested.

All Operator Message 235 was previously issued to advise Operators of an incident in which the right hand main landing gear collapsed following landing. A Bombardier / Goodrich team has been dispatched to the site to support the ongoing investigation, along with the Transportation Safety Board of Canada.

Although there have been no findings to-date, we have conducted a preliminary engineering review of the limited information available at this time. Based on this review, Operators may wish to consider performing the following interim actions on a one time basis:

**Safety Reminder: Insert the MLG Lock Pin and ensure it fits freely (Refer to Ramp Service Manual Chapter 2 page 45) prior to doing any work in the landing gear area including the recommended tasks below.**

Within the next 100 flight hours it is recommended to complete the following tasks on a one time basis:

- Clean and perform a General Visual Inspection (GVI) of the MLG stabilizer stay hinge points for general condition and security
- Clean and inspect (GVI) the MLG stabilizer stay – brace for general condition and security

At the next 'A'-Check it is recommended to pay special attention to the following task:

- Lubricate all MLG Stabilizer Stay hinge points and ensure joints freely accept grease (Refer to AMM TASK 12-20-01-640-803) as per the 'A' check. Special attention should be directed to the joints marked on the illustration below, on both sides of the stay brace.

Operators will be advised as the investigation progresses and further information becomes available.

**Figure 1: Inspection Areas**

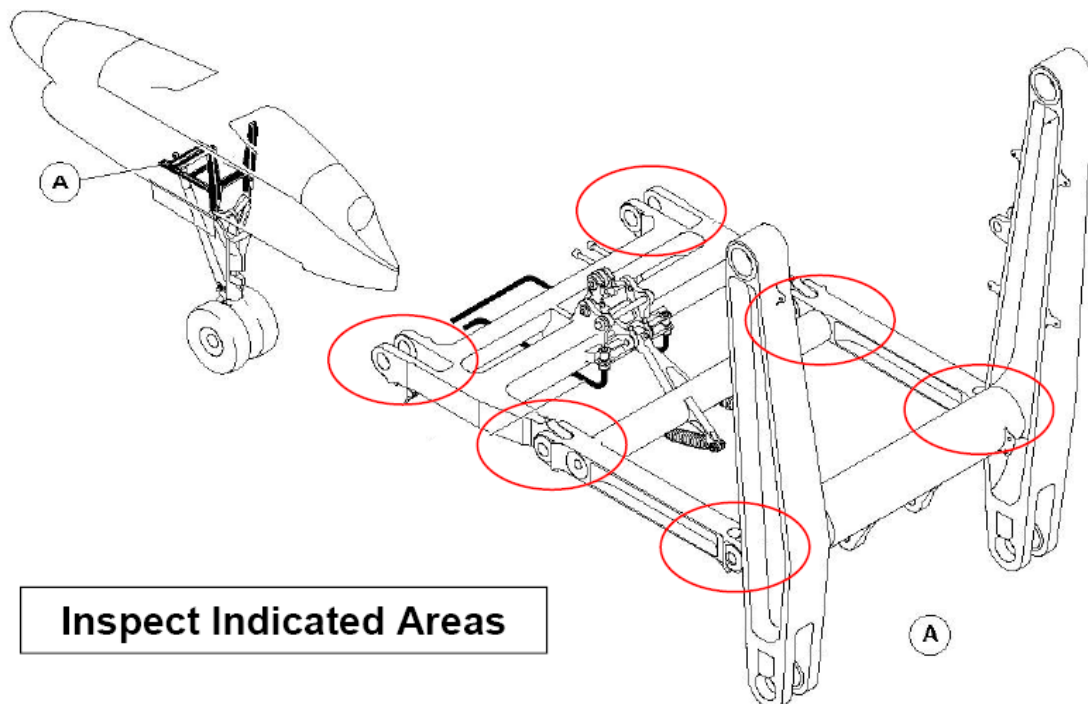

**Figure 2: Inspection Area Pictures**

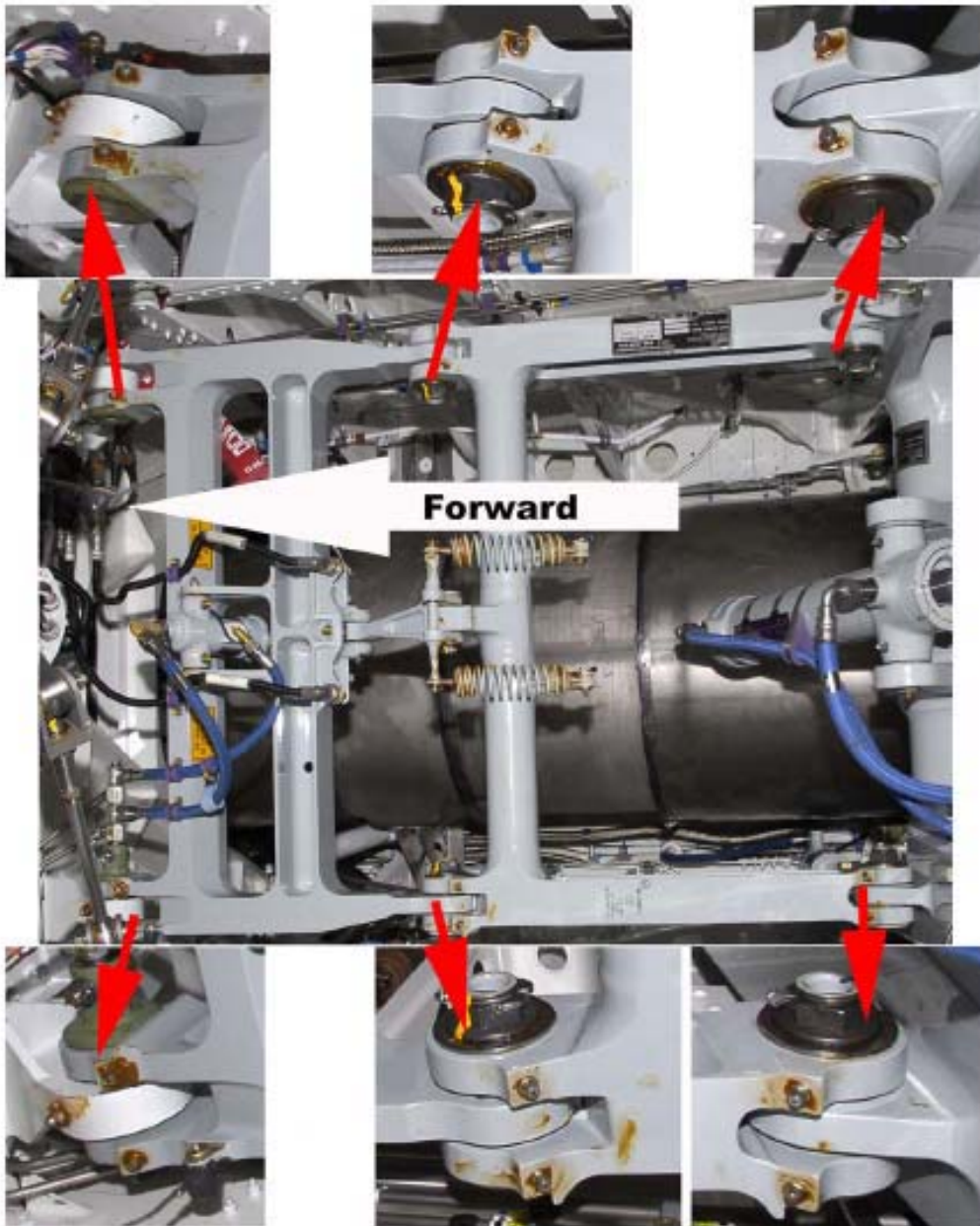

Please direct responses and inquiries to the Technical Help Desk in Toronto at telephone (416) 375-4000 or facsimile (416) 375-4539 or e-mail: [thd.qseries@aero.bombardier.com](mailto:thd.qseries@aero.bombardier.com).

Barry Wilkins, Principal Engineer, In-Service Engineering & Technical Support, and Martin Elliott, Director, In-Service Engineering & Technical Support, Bombardier Aerospace.



## **Bilag 5**







**Aircraft Accident Notification Report  
SK2748/11SEP2007**

**Occurrence**

Information	Specification/Description
Date	11 Sept 2007
Time	2235 UTC
Location	VNO-EYVI Vilnius- Lithuania Longitude: 25, 17, 16 E Latitude: 54,38,13 N Elevation: 646 ft
Last point of departure	CPH-EKCH (Copenhagen) Off block 1945 UTC Airborne 1952 UTC
Point of Intended Landing	PLQ-EYPA Palanga Airport
Flight number	SK2748
Radio Call sign	Scandinavian 2748
Type of operations	Commercial
Phase of operation	Landing VNO-EYVI TD 2236 UTC
Flight level	N/A
Description of the occurrence	Diversion to Vilnius due to malfunction LDG. Right main landing gear collapsed after touchdown.
Fire	No
Other	No injuries reported.

**Aircraft Information**

Information	Specification/Description
Manufacture	Bombardier Aerospace Inc.
Model	DHC-8-403 76 Seats
Registration	LNRDS Göte Viking
Serial number	MSN 4035
Year of manufacture	31 JAN 2001 Date of acceptance 02 FEB 2001
Cert. of Airworthiness, exp, date	31 MAR 2008
Total time / cycles	FH 11366,55 FC 14224
Time since last maintenance and type of maintenance	Last Minor Check L-Check 2007-09-06 at 11337,78 FH Last Major Check A1 & A2 2007-06-25 at 10908,49 FH

Engine(s) type and model	PW150A / 4580 SHP
Propeller(s)/rotor(s), manufacture and type	Dowty Aerospace Propellers - R408/6-123-F/1
Total time / cycles	<p>Eng LH PN 3121627-01 SN PCE-FA0027  TSN FH 9958,14  TSN FC 12449  TSI FH 998,14  TSI FC 1102  TSO FH 9958,14  TSO FC 12449  TSM FH 998,14  TSM FC 1102</p> <p>Eng RH PN 3121627-01 SN PCE-FA0232  TSN FH 3827,55  TSN FC 4738  TSI FH 1196,55  TSI FC 1322  TSO FH 3827,55  TSO FC 4738  TSM FH 3827,55  TSM FC 4738</p> <p>Propeller LH PN 697070003 SN DAP0061  TSN FH 11553,24  TSN FC 13411  TSI FH 1555,34  TSI FC 1712  TSO FH 1555,34  TSO FC 1712  TSM FH 1555,34  TSM FC 1712</p> <p>Propeller RH 697070003 SN DAP0110  TSN FH 10521,63  TSN FC 1583  TSI FH 843,63  TSI FC 943  TSO FH 1382,63  TSO FC 1583  TSM FH 1382,63  TSM FC 1583</p>

Landing Gear	NLG PN 47200-15 SN MA0043 TSN FH 11366,55 TSN FC 14224 TSI FH 11366,55 TSI FC 14224
	LH MLG PN 46100-29 SN MA0081 TSN FH 11366,55 TSN FC 14224 TSI FH 11366,55 TSI FC 14224 TSO FH 11366,55 TSO FC 14224 TSM FH 11366,55 TSM FC 14224
	RH MLG PN 46100-29 SN MA0079 TSN FH 11366,55 TSN FC 14224 TSI FH 11366,55 TSI FC 14224 TSO FH 11366,55 TSO FC 14224 TSM FH 11366,55 TSM FC 14224

Insurance company	AON Aviation
Insurance company's address	8 Devonshire Square London-UK
Insurance company's phone number	+44 207 623 55 00
Exp. date	Issued 30 Nov 2006 Valid until Midnight 30 <sup>th</sup> November 2007
Certificate of Airworthiness	Number N/A Validity 31 MAR 2008
Owner	Aviator Ltd Ugland House P.O Box 309 Georg Town, Grand Cayman British West Indies
Operator	Scandinavian Airlines System SE 19587 Stockholm, Sweden +46 8 797 00 00
Damage to Aircraft	LDG collapsed
Fire	No
Total number of persons onboard	51 adults + 1 infant
Crew	2/2
Passengers	47 adults + 1 infant
Infants	1



**Weather details at time of occurrence****EYVI local weather 11SEP at 22:30 UTC**

Information		Specification/Description
Wind	Direction	Variable
	Velocity	1 kts
Gust	Direction	None
	Velocity	
Turbulence	None/Light	None
	Moderate/severe	
Visibility	Visibility (m)	2900 m in mist/fog patches
	RVR	-
Temperature	Dew point	10
	OAT	9
Pressure	QNH	1015
Clouds	Type amount	Bkn 4900 ft
	Height	Ovc 5600 ft
Precipitation	None/Rain	None
	Drizzle/Snow	
	RASN/Hail	
Intensity	Light/Showers	
	Moderate/Severe	
Icing	None/Light	None
Light conditions	Daylight	Night
General weather in the area	VMC	
	IMC	Mist

**Other information**

**SAS DHC-Q400 fleet was grounded by NPH Technical Operations, Geir Steiro, at 2213 UTC.**

NPH Scandinavian Flight Operations	NPH Scandinavian Technical Operations	NPH Scandinavian Ground Operations	NPH Crew Training
Stockholm 12 Sept 2007	Stockholm 12 Sept 2007	Stockholm 12 Sept 2007	Stockholm 12 Sept 2007
 Ola Reinholdt	 Geir Steiro	 Tomas Linden	 FOR Torben Løvetofte



## **Bilag 6**





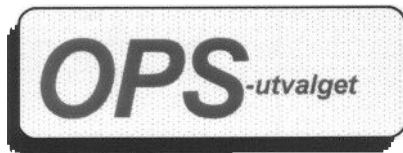

2007-09-12

STK 2007-0280-1

De skandinaviske luftfartsmyndigheternas  
samarbetsorgan för flygsäkerhetsfrågor

**STK** DET SKANDINAVISKE TILSYNSKONTOR  
DENMARK NORWAY SWEDEN

Accountable manager  
John Dueholm  
Scandinavian Airlines System  
Denmark-Norway-Sweden  
STODA

Kopia:  
STOOM  
STOOG  
STOOF  
STODO-X  
STODG

### **Midlertidig inddragelse af luftdygtighedsbeviser på luftfartøjer af typen Bombardier DHC8-Q400 .**

Dette brev bekræfter OPS-utvalgets beslutning om, med øjeblikkelig virkning, at inddrage luftdygtighedsbeviserne på samtlige luftfartøjer af ovennævnte type opereret af SAS, eller udlejet af SAS til anden luftfartsvirksomhed med fortsat registrering på dansk, norsk eller svensk register.

Ovennævnte er i overensstemmelse med hvad der blev meddelt SAS kl. ca. 02:00 dags dato via telefon af undertegnede.

Beslutningen er truffet på baggrund af havari med luftfartøjet LN-RDK den 9. september 2007 i Aalborg, samt havariet med LN-RDS den 11. september 2007 i Vilnius, hvor højre hovedunderstel i begge tilfælde kollapsede under landing.

Luftdygtighedsbeviserne inddrages med hjemmel i Kommissionsforordning 1702/2003 Part 21, §21B330, idet luftfartøjstypen på baggrund af de indtrufne havarier ikke overholder kravene i forordningens §21A181(a)1.

OPS-Udvalget meddeler SAS når luftdygtighedsbeviserne igen kan udleveres.

Inddragelsen omfatter følgende luftfartøjsindivider:

LN-RDA, LN-RDB, LN-RDC, LN-RDD, LN-RDE, LN-RDF, LN-RDG, LN-RDH, LN-RDI, LN-RDJ, LN-RDL, LN-RDM, LN-RDO, LN-RDP, LN-RDQ, LN-RDR, LN-RDT, OY-KCD, OY-KCE, OY-KCF og OY-KCG.

På vägnarna av luftfartsmyndigheterna i Danmark, Norge och Sverige.

  
Kurt Lykstoft Larsen

STK - Det Skandinaviske Tilsynskontor  
Luftfartsstyrelsen  
SE-601 73 NORRKÖPING  
Visiting address: Bergkällavägen 32  
SOLLENTUNA, Sweden

Phone  
+ 46 (0)11 41 52100

E-mail: [stk@luftfartsstyrelsen.se](mailto:stk@luftfartsstyrelsen.se)  
SITA CODE BMAZVSK

Facsimile  
+ 46 (0)11 41 52490

OPS-utvalget is the Scandinavian Civil Aviation Authorities' board for coordination of safety regulations and supervision of jointly certified airlines and other aviation enterprises. STK- Det Skandinaviske Tilsynskontor - is an office under OPS-utvalget for supervision of these entities



## **Bilag 7**



European Aviation Safety Agency  
Postfach 10 12 53  
D-50452 Köln  
Germany

Attention: Certification Director Dr. Norbert Lohl.

Date:	Our ref.:	Contact person:
12. September 2007		Per Veingberg
Your letter of:	Deres ref.:	Direct no.:

**Subject: Bombardier Dash 8 Q400 aircraft, Main Landing Gear collapse.**

Please be advised, that for the above type of aircraft, on 9. September 2007 i Aalborg, Denmark, and on 11. September 2007 in Vilnius Lithuania, 2 identical accidents has occurred, where RH Main Landing Gear collapsed during landing, with the result, that the aircraft RH wing contacted the runway, and the aircraft crashed.

In both cases, no persons were seriously harmed.

The aircrafts were both operated by Scandinavian Airlines Systems (SAS).

For the accident in Denmark, the Danish Air Accident Investigation Board is investigating the accident, assisted by the Norwegian Air Accident Board, the Canadian Air Accident Board and the manufacturer Bombardier.

Further SAS together with Bombardier, surveyed by the Civil Aviation Authorities in Denmark, Norway and Sweden, are performing an internal investigation to state the cause of the failure of the Main Landing Gear.

At the moment, Bombardier Dash 8 Q400 aircrafts on register in Denmark, Norway and Sweden are temporarily grounded by reworking the individual Certificate of Airworthiness.

We do not know very much about the cause of the Gear collapse, however preliminary investigations seems to indicate a problem (possible fracture) of components in the upper part of the Gear downlock overcentering mechanism.

We have enclosed relevant documents for Your information, and expect Transport Canada/Bombardier to contact you soon about the matter.

For further information, please do not hesitate to contact me as stated above, mobile phone +4540930330 or e-mail [peve@slv.dk](mailto:peve@slv.dk).

Yours sincerely



Per Veingberg  
Technical Director

Enclosure: SAS AAN Report LN-RDK  
SAS AAN Report LN-RDS  
Bombardier, SAS inspection document  
Bombardier AOM 235  
Bombardier AOM 237

## **Bilag 8**





# Preliminary engineering analysis 11/9 16.00 hrs

Q400 LN-RDK

Accident Aalborg Sept. 9, 2007

# An analysis is performed of engineering data

- The purpose of the analysis is to map and possibly identify items which may have impacted on the accident, in order to have a background for further course of action
- The analysis will not and can not conclude or speculate on the cause of the accident
- The analysis will only assess the available data and see if it is justifiable and reasonable to perform a fleet inspection based on the result of the analysis

## The following has been analysed:

- DTR data has been checked for repeated malfunctions of ATA 32
- All reliability data for the aircraft individual and the fleet is being analysed. Preliminary analysis concluded for 2007.
- All non-routine work related to RDK the last year has been/is being analysed.

# Preliminary results of the analysis

- **Two instances of non-routine work the last three months involved the R/H MLG on RDK**
  - June 3rd: Rod end R/H mlg loose in piston end
  - August 14th: RH down lock spring replaced
- **Feedback from STOOF**
  - Sept 6th: RH MLG down lock spring broken (uncertain if it is on RDK)

# Rod end R/H mlg loose in piston end

- Will have to be investigated further, the problem was fixed and the aircraft was released again and has flown 3 months since.
- Pictures showed the actuator rod eye end ripped loose from rod. Most likely caused by forces at the accident. No data available regarding the piston end, but it appears as if the actuator was in normal position before the accident.
- Limited inspection of the actuator judged not to be an effective measure.

# RH down lock spring

- Analysis of the system shows that it is a redundant system (2 down-lock springs) and the spring is only holding the brace in the locked position. RDK never locked the brace. The locked position is normally held by the lock actuator and the spring is the redundant system in case of loss of hydraulic pressure. Preliminary inspection of RDK indicated that the springs were intact and correctly installed.
- Based on this it is **not likely** that an inspection of the down lock spring would have a preventive effect on the fault experienced on RDK and it is not considered an effective measure

# Assessment of pictures from the accident site

- Pictures revealed great damage to the aircraft, most damage appears to come from forces at the accident.
- MLG suffered severe damage with broken links, ruptured downlock torque tube, actuator eye end ripped off etc.
- Impossible to assess from the pictures if damage caused the accident or was caused by it.

# Conclusion from preliminary analysis

- No trend or problem area related to the MLG collapse could be identified, either on the individual A/C or the fleet as a whole.
- Pictures revealed only indications that the problem started with the mechanical function of the MLG.



# Recommended action

- After conferring with Bombardier and Goodrich it was concluded that a precautionary measure should be performed even though the data was not conclusive
- General inspection of the MLG mechanical components (normal MPD insp.) and a detailed inspection and lubrication of the MLG down-lock brace is the recommended action



## **Bilag 9**



## Bombardier Q400

### All Operator Message No. 237A

---

ATTN: Director/Manager of: Maintenance  
Engineering  
Quality Control  
Flight Operations  
Procurement/Spares

DATE: 12 September 2007

ATA: 3210 MODEL: Q400

SUBJECT: In-service Incident – Second Occurrence of Right Main Landing Gear Collapse After Landing

REFERENCE: /A/ AOM 235, In-service Incident – Right Main Landing Gear Collapse After Landing  
/B/ AOM 236A, Update - In-service Incident – Right Main Landing Gear Collapse After Landing  
/C/ AOM 238, Transport Canada Airworthiness Directive (AD) CF-2007-20 Issued Against DHC-8-400 Main Landing Gear

The following message is being sent to all Bombardier Q400 Operators and Bombardier Aerospace Field Service Representatives.

This message contains information requiring attention and/or action. Please ensure timely and appropriate distribution within maintenance and flight operations departments.

---

#### DISCUSSION:

Original issue of this AOM has been superseded by Transport Canada AD CF-2007-20 Issued Against DHC-8-400 Main Landing Gear

Please direct responses and inquiries to the Technical Help Desk in Toronto at telephone (416) 375-4000 or facsimile (416) 375-4539 or e-mail: [thd.qseries@aero.bombardier.com](mailto:thd.qseries@aero.bombardier.com).

Alisa Turk, Manager Technical Help Desk, and Martin Elliott, Director, In-Service Engineering & Technical Support, Bombardier Aerospace.



## **Bilag 10A**





# BOMBARDIER

# REPAIR DRAWING (RD)

1 TITLE <b>Inspection procedure for retraction actuators p/n 46550-7 or 46550-9 rod end.</b>			2 RD NUMBER <b>8/4-32-059</b>	
			3 SECTION <b>1</b>	4 SHEET <b>1</b>
5 PRIME DESIGN ACTIVITY <b>BOMBARDIER INC., DOWNSVIEW 71867</b>	6 ADDITIONAL LIMITATIONS <b>NONE</b>	7 SERIES <b>DHC-8-400</b>	8 APPLICABILITY <b>Models 400, 401 and 402</b>	

**9 DESCRIPTION**

This RD defines an inspection procedure for retraction actuators p/n 46550-7 or 46550-9 rod end.

This RD is to be accomplished in conjunction with Goodrich SCR 086-07 rev. NC.

The procedure involves removing the rod end of the retraction actuator assembly in accordance with SCR 086-07 rev. NC and inspecting affected parts for any signs of corrosion or wear.

**No corrosion or wear damage is allowed.**

**Provided the components are free of any damage re-assemble retraction actuator in accordance with SCR 086-07 rev. NC.**

The details of this procedure are covered by RD 8/4-32-059 section 1.

Sheet 1 Issue 1  
Sheet 2 Issue 1

10 ISSUE	1			
11 DATE	12-Sep-07			
12 PREPARED BY	A. Vinitsky			
13 STRESS	N/A			
16 DESIGN AUTHORITY	M. Babin			
14	N/A			
15	N/A			
17 DAO AUTHORITY	Shawn Harts			

18  THE TECHNICAL CONTENT OF THIS DOCUMENT IS APPROVED UNDER THE DESIGN AUTHORITY OF TRANSPORT CANADA DESIGN APPROVAL ORGANIZATION DAO NO. 83-0-02

NO ENGINEERING DISPOSITION FOR APPROVAL BY OPERATOR'S LOCAL AIRWORTHINESS AUTHORITY

THIS REPAIR DRAWING HAS BEEN PREPARED ON THE BASIS OF INFORMATION SUPPLIED TO BOMBARDIER INC. BY THE OPERATOR OR HIS AGENT. IT IS THE RESPONSIBILITY OF THE OPERATOR OR HIS AGENT TO VERIFY THAT THE INFORMATION SUPPLIED IS COMPLETE AND ACCURATE. BOMBARDIER INC. DOES NOT ACCEPT RESPONSIBILITY FOR ANY CONSEQUENCE RESULTING FROM INCOMPLETE OR INACCURATE REPORTING OF THE DAMAGE / DISCREPANCY.

THE INFORMATION, TECHNICAL DATA AND DESIGNS DISCLOSED HEREIN ARE THE EXCLUSIVE PROPERTY OF BOMBARDIER INC. OR CERTAIN PROPRIETARY RIGHTS OF OTHERS AND ARE NOT TO BE USED OR DISCLOSED TO OTHERS WITHOUT THE WRITTEN CONSENT OF BOMBARDIER INC. THE RECIPIENT OF THIS DOCUMENT BY ITS ACCEPTANCE AND USE AGREES TO HOLD IN CONFIDENCE THE TECHNICAL DATA AND DESIGNS CONTAINED HEREIN. THE FOREGOING SHALL NOT APPLY TO PERSONS HAVING PROPRIETARY RIGHTS TO SUCH INFORMATION, TECHNICAL DATA OR SUCH DESIGNS TO THE EXTENT THAT SUCH RIGHTS EXIST.

10 ISSUE	1				2 RD NUMBER	3 SECTION	4 SHEET
					8/4-32-059	1	2

## Retraction actuator assembly p/n 46550-7/-9

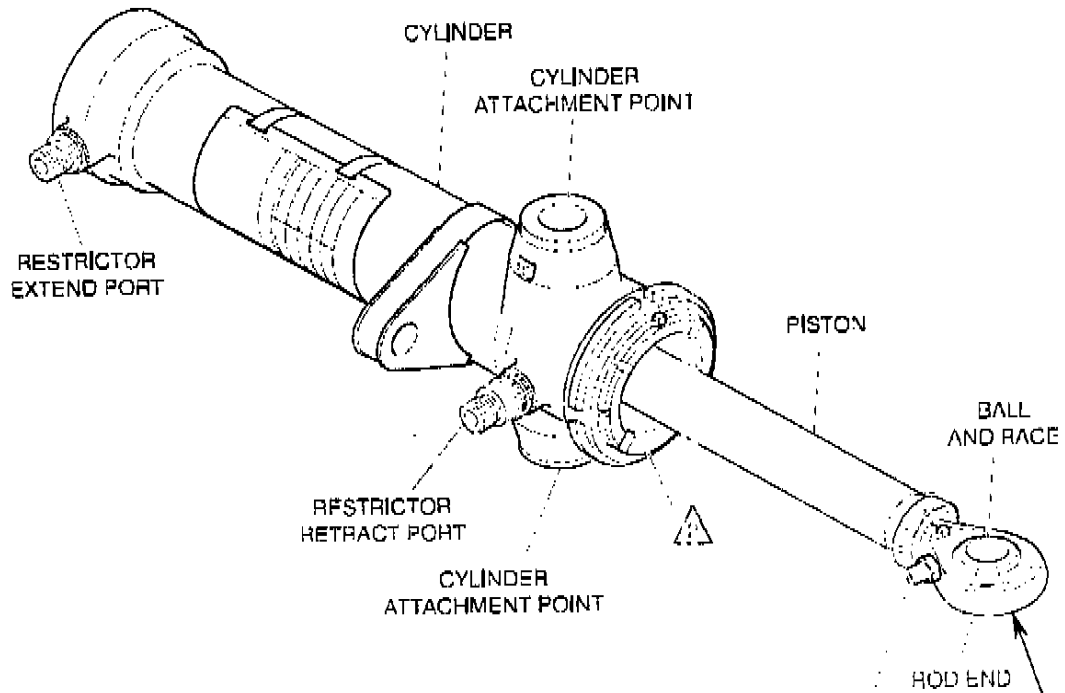

Remove the rod end of the retraction actuator assembly in accordance with SCR 086-07 rev. NC

Inspect affected parts for any signs of corrosion or wear.

No corrosion or wear damage is allowed.

Provided the components are free of any damage re-assemble retraction actuator in accordance with SCR 086-07 rev. NC

## **Bilag 10B**



		<b>SERVICE CONCESSION REQUEST</b>			SCR NUMBER	REV	PROG
					SCR 086-07	NC	2130
AIRCRAFT DETAILS					INDICATE IF <b>A.O.G.</b> >> <input checked="" type="checkbox"/> <<		
EVENT DATE (Y/M/D)	AIRLINE	A/C S/N	TSN	CSN			
ANY	ALL	4001 AND SUB					
ITEM	PART NO.	NAME			S/N	TSN	CSN
N.H.A ⇄							
N.H.A ⇄	46550-71-9	RETRACTION ACTUATOR			ALL		
PART ⇄	46570-11-3	PISTON			ALL		
LIMITED FLIGHT REQUESTED YES <input type="checkbox"/> NO <input checked="" type="checkbox"/> (IF YES, AUTHORIZED ENGINEER SIGNATURE REQUIRED)		REQUEST CATEGORY			AFFECTED SYSTEM		
		IN-SERVICE PROBLEM <input checked="" type="checkbox"/>			MLG <input checked="" type="checkbox"/>	BRAKING <input type="checkbox"/>	NLG <input type="checkbox"/>
INDICATE FC OR FH LIMITATION: FC* _____ FH* _____ *WHICH EVER COMES FIRST		DISPOSITION SUMMARY			PREVIOUS CONCESSIONS GRANTED FOR THIS SERIAL NUMBER COMPONENT		
IF ONLY FC IS SPECIFIED INDICATE FH NOT RELEVANT <input type="checkbox"/>		NORMAL USE AFTER REPAIR <input type="checkbox"/> LIMITED SERVICE <input type="checkbox"/> TEMPORARY REPAIR <input type="checkbox"/> REMOVE & REPAIR <input type="checkbox"/> REPLACE PART <input type="checkbox"/>					
OR SPECIFY LIMITATION IN TERMS OF AIRCRAFT CHECKS: A <input type="checkbox"/> C <input type="checkbox"/> L <input type="checkbox"/> X					DATE RAISED 2007/09/12		
SCR RAISED BY					B. WEBER		

ITEM	PROBLEM DESCRIPTION
1	THERE HAVE BEEN 2 INSTANCES OF SEPARATION OF ROD END P/N P3A2750 AND PISTON P/N 46570-11-3. INSPECTION OF THREAD CONDITION REQUIRED INACCORDANCE TO TRANSPORT CANADA AIRWORTHINESS DIRECTIVE.
REPORTED CAUSE OF PROBLEM:	
ADDITIONAL INFORMATION ATTACHED <input type="checkbox"/>	
>> SEE SHEET 2 AND SUBS FOR MORE INFORMATION <<	

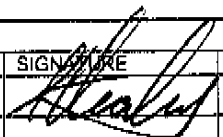
		<b>SERVICE CONCESSION REQUEST</b>			SCR NUMBER SCR 086-07	REV NC	PROG 2130
		AIRCRAFT DETAILS			INDICATE IF <b>A.O.G.</b> ➤ ➤ <input checked="" type="checkbox"/> ➤ ➤		
EVENT DATE (Y/M/D)	AIRLINE	A/C S/N	TSN	CSN			
ANY	ALL	4001 AND SUB					
ITEM	PART NO.	NAME		S/N	TSN	CSN	
N.H.A ⇒							
N.H.A ⇒	46550-7/-9	RETRACTION ACTUATOR		ALL			
PART ⇒	46570-1/-3	PISTON		ALL			
CONTINUATION SHEET / INSTRUCTIONS							
ITEM	<ol style="list-style-type: none"> <li>1. WITH ACTUATOR INSTALLED ON AIRCRAFT, REMOVE LOCKWIRE AND BACK OFF JAM NUT AS REQUIRED TO DISENGAGE LOCKING FEATURE.</li> <li>2. DISASSEMBLE AS REQUIRED, REMOVE ACTUATOR ROD END PIN P/N 46460-1 FROM MAIN LANDING GEAR SHOCK STRUT ASSEMBLY</li> <li>3. FULLY COMPRESS PISTON (ACTIVATE LANDING GEAR ALTERANTE EXTENSION DOOR TO PORT LANDING GEAR HYDRAULICS TO RETURN).</li> <li>4. SECURE PISTON, AND REMOVE ROD END FROM PISTON.</li> <li>5. IF ROD END P/N P3A2750 DOES NOT EASILY BACK OUT OF PISTON, REMOVE RETRACT ACTUATOR P/N 46550-7/-9 FROM GEAR ASSEMBLY.                         <ul style="list-style-type: none"> <li>- REPLACE WITH NEW OR REFURBISHED RETRACT ACTUATOR P/N 46550-7/-9 WHICH HAS INCORPORATED CIC PER DWG 46550, E.O.3NC1 (REF. TO BOMBARDIER AMM)</li> <li>- IF ACTUATOR DOES NOT HAVE CIC INCORPORATED SEE SECTION A OF THIS SCR.</li> </ul> </li> <li>6. IF ROD END P/N P3A2750 BACKS OUT OF PISTON EASILY, COMPLETELY REMOVE ROD END AND CONTINUE WITH OPERATIONS 6 THRU 16.</li> <li>7. VISUALLY INSPECT ROD END P/N P3A2750 FOR EVIDENCE OF CORROSION CONTAMINATION IN THREADS.</li> <li>8. VISUALLY INPSECT PISTON P/N 46570-1/-3 THREADS AND THREAD RELIEF AREA FOR EVIDENCE OF CORROSION AND/OR DAMAGE AND/OR PITTING (REF. VIEW A, PAGE 3).</li> <li>9. IF CORROSION IS FOUND IN THREADED AREA OF PISTON P/N 46570-1 REMOVE AND REPLACE ACTUATOR ASSEMBLY P/N 46550-7/-9, IN ACCORDANCE WITH BOMBARDIER AMM REQUIREMENTS</li> <li>10. IF NO CORROSION IS FOUND, COAT ACTUATOR THREADS AND THREAD RELIEF AND ROD END THREADS, WITH CIC MASTINOX 6865K.</li> <li>11. RE-INSTALL ROD END INTO PISTON</li> <li>12. MECHANICALLY REMOVE ACTUATOR FROM YOKE ASSEMBLY (NOTE: HYDRAULIC DISCONNECTION NOT REQUIRED).</li> <li>13. USING TOOL NUMBER CG 56806, ADJUST ROD END RETRACTED LENGTH AS REQUIRED (REF. SCR PAGE 4), TORQUE JAM NUT TO 660-980 IN-LBS, SAFETY LOCK WIRE PER MS 33540.                         <ul style="list-style-type: none"> <li>- OPTIONAL PROCEDURE FOR RIGGING ACTUATOR LENGTH: RIG ACTUATOR TO NOMINAL RETRACTED LENGTH PER TOOL DRAWING AT-SCR 086-07(REF. DIM 4.286 INCH), AND TORQUE JAM NUT TO 660-980 IN-LBS, SAFETY LOCK WIRE PER MS 33540.</li> <li>- NOTE: IF OPTIONAL PROCEDURE IS USED, GEAR SWINGS ARE REQUIRED (2 POWERED CYCLES AND 1 ALTERNATE RELEASE TO VERIFY FUNCTIONAL CAPABILITY).</li> </ul> </li> </ol>						
<b>DISPOSITION AUTHORIZATION</b>							
ENGINEER	NAME (PRINT)	SIGNATURE	DATE(Y/M/D)	AUTHORIZED ENGINEER OR HIGHER ENGINEERING AUTHORITY  DATE:			
STRESS	S.HEALEY		9/12/2007				
OTHER (SPECIFY)							
				<b>Page 2 of 4</b>			

		<b>SERVICE CONCESSION REQUEST</b>			SCR NUMBER SCR 086-07	REV NC	PROG 2130
		AIRCRAFT DETAILS			INDICATE IF <b>A.O.G.</b> ➤➤ <input checked="" type="checkbox"/> ⚡ ⚡➤		
EVENT DATE (Y/M/D)	AIRLINE	A/C S/N	TSN	CSN			
ANY	ALL	4001 AND SUB					
ITEM	PART NO.	NAME			S/N	TSN	CSN
N.H.A ➡							
N.H.A ➡	46550-71-9	RETRACTION ACTUATOR			ALL		
PART ➡	46570-1/-3	PISTON			ALL		

**INSTRUCTIONS / CONTINUATION SHEET**

14. RE-INSTALL ACTUATOR ONTO YOKE ASSEMBLY.
15. EXTEND PISTON AND RE-ATTACH TO SHOCK STRUT ASSEMBLY USING PIN P/N 46460-1, AND TORQUE IN ACCORDANCE AMM REQUIREMENTS.
16. COMPLETE OPERATIONAL AND/OR FUNCTIONAL CHECKS OF LANDING GEAR SYSTEM AS REQUIRED IN STEP 13 TO RETURN THE AIRCRAFT TO SERVICE.

**SECTION A - APPLICABLE TO EXISTING ACTUATORS ASSEMBLED WITHOUT MASTINOX.**

1. DISASSEMBLE AS REQUIRED TO REMOVE ROD END P/N P3A2750 FROM ACTUATOR ASSEMBLY PER CMM REQUIREMENTS.
2. INSPECT - ENSURE NO EVIDENCE OF CORROSION ON ACTUATOR PISTON THREADS OR ROD END THREADS.
3. COAT ACTUATOR THREADS AND THREAD RELIEF AS WELL AS ROD END THREADS, WITH CIC MASTINOX 6865K.
4. RE-INSTALL ROD END ONTO ACTUATOR ASSEMBLY.
5. ADJUST ACTUATOR RETRACTED LENGTH USING TOOL CG 56806 REQUIREMENTS OR IN ACCORDANCE WITH CMM REQUIREMENTS.
6. TORQUE JAM NUT TO 660-980 IN-LBS AND SAFETY LOCKWIRE PER MS 33540.
7. COMPLETE PER UNIT CMM REQUIREMENTS (NOTE: FULL ACCEPTANCE TEST NOT REQUIRED).

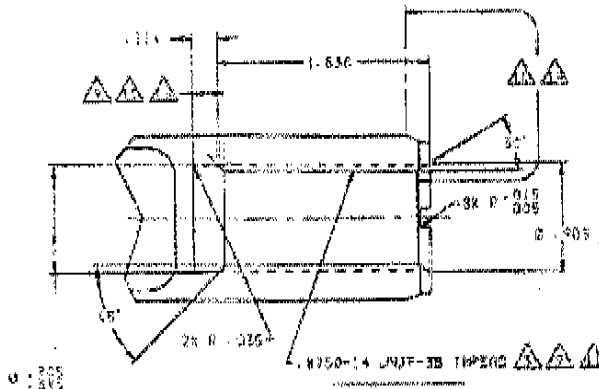

**VIEW A**

DISPOSITION AUTHORIZATION				AUTHORIZED ENGINEER OR HIGHER ENGINEERING AUTHORITY
	NAME (PRINT)	SIGNATURE	DATE (Y/M/D)	
ENGINEERING	S.HEALEY		9/12/2007	DATE:
STRESS				
OTHER (SPECIFY)				





## **Bilag 10C**







# **Bilag 11**





2007-09-13

STK 2007-0280-1

De skandinaviska luftfartsmyndigheternas  
samarbetsorgan för flygsäkerhetsfrågor

**STK** DET SKANDINAVISKE TILSYNSKONTOR  
DENMARK NORWAY SWEDEN

Accountable manager  
John Dueholm  
Scandinavian Airlines System  
Denmark-Norway-Sweden  
STODA

Kopia:  
STOOM  
STOOG  
STOOF  
STODO-X  
STODG

### **Tilladelse til færgeflynning af luftfartøjer af typen Bombardier DHC8-Q400.**

Med henvisning til OPS-udvalgets brev af 12. september 2007, som midlertidigt inddrager luftdygtighedsbeviset på en række angivne luftfartøjsindivider af ovennævnte type, meddeles herved tilladelse til færgeflynning af luftfartøjerne i relevant omfang, med begrundelse som anført i, samt i overensstemmelse med retningslinierne fastsat i EASA Emergency Airworthiness Directive AD No:2007-0252-E dateret 13. september 2007.

Tilladelsen omfatter i relevant omfang følgende luftfartøjsindivider:  
LN-RDA, LN-RDB, LN-RDC, LN-RDD, LN-RDE, LN-RDF, LN-RDG, LN-RDH, LN-RDI, LN-RDJ, LN-RDL, LN-RDM, LN-RDO, LN-RDP, LN-RDQ, LN-RDR, LN-RDT, OY-KCD, OY-KCE, OY-KCF og OY-KCG.

På vegne af luftfartsmyndighederne i Danmark, Norge och Sverige.

Kurt Lykstoft Larsen





## **Bilag 12**





## Foreløbig status for undersøgelser af havari med LN-RDK d. 9. september 2007

### Flyvningens historie

Havariet vedrørte et luftfartøj i rutefart fra Københavns Lufthavn Kastrup til Aalborg Lufthavn.

Flyvningen fra København til anflyvningen af Aalborg var normal.

Under anflyvningen til Aalborg blev betjeningshåndtaget for landingsstellet aktiveret. Efter udløbet af sekvensen for sænkning af landingsstellet viste cockpitindikatorerne for landingsstel to grønne og et rødt lys. De to grønne lys viste, at venstre landingsstel og næsestel var sænket og låst. Det røde lys viste, at det højre landingsstel ikke var låst.

Landingen blev afbrudt.

En alternativ procedure for sænkning af landingsstellet blev foretaget. Også derefter viste cockpitindikatorerne, at højre landingsstel ikke var låst.

En visuel inspektion af landingsstel blev foretaget.

Besætningen forberedte dernæst luftfartøjet og passagerne på en nødlanding.

Luftfartøjet blev landet først på venstre landingsstel og umiddelbart efter på højre landingsstel, som kollapsede.

Luftfartøjet skred ud mod højre og kom til standsning i sikkerhedszonen ved siden af landingsbanen, hvilende på den nederste del af flykroppen og vingetippen.

Luftfartøjet blev væsentligt skadet, og nogle passagerer fik mindre skader

Havariet indtraf i dagslys under visuelle meteorologiske betingelser (VMC).

## Tekniske undersøgelser

De tekniske undersøgelser har været koncentreret om det højre landingsstel. En skitsefigur heraf er vist nedenfor.

Under undersøgelserne blev det afdækket, at landingsstelsaktuatorens øjebolt var separeret fra aktuatorens stempel.

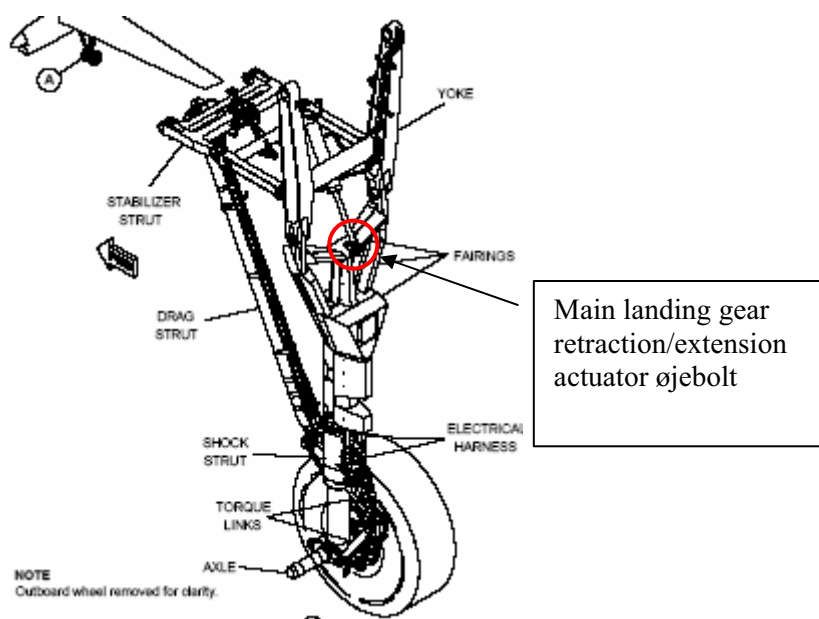

Landingsstellets aktuator, øjebolt og afstivningsstabilisator blev demonteret fra luftfartøjet for videre undersøgelse på et laboratorium.

En undersøgelse af aktuatorstemplets indre gevind blotlagde tilstedeværelsen af korrosion, som har svækket materialet og ledte til separationen af øjebolten fra aktuatorstemplet. Denne separation var hovedfaktoren ledende til understellets kollaps.

Myndighederne er blevet informeret om situationen og har udsendt et luftdygtighedsdirektiv, der kræver umiddelbart handling fra operatørerne.

## Videre forløb

Havarikommissionen mener gennem de foreløbige undersøgelser at have fastslået årsagen til det indtrufne havari. Havarikommissionens undersøgelser fortsætter med henblik på at afdække yderligere faktorer i forbindelse med havariet.

## **Bilag 12A**





**LIETUVOS RESPUBLIKOS SUSISIEKIMO MINISTERIJOS  
ORLAIVIŲ AVARIJŲ BEI INCIDENTŲ TYRIMŲ VADOVAS  
MINISTRY OF TRANSPORT AND COMMUNICATIONS  
OF THE REPUBLIC OF LITHUANIA  
CHIEF INVESTIGATOR OF AIRCRAFT ACCIDENT AND INCIDENT**

**PRELIMINARY ACCIDENT REPORT**

Aircraft	DHC-8-402
Manufacturer	Bombardier Aerospace Inc.
State of Registry	Norway
Registration	LN-RDS Göte Viking
Operator	SAS
Date/Time	11 September 2007, 22.35 UTC
Position of occurrence	Vilnius Airport, Lithuania
Persons on board	52
Injuries	Nil
Damage	Substantial

The accident investigation commission appointed by the Chief Investigator of Aircraft Accident and Incident is presently conducting an investigation into an accident concerning aircraft DHC-8-402 LN-RDS. The Chief Investigator acts as the Investigator in Charge. The information presented in this report is preliminary.

**History of flight**

The aircraft was operating a scheduled passenger flight No SK2748 from Copenhagen Airport Kastrup (EKCH) to Palanga Airport (EYPA) in Lithuania. The flight from EKCH till the approach to EYPA was normal. At the altitude of 2000 FT the landing gear was selected Down. When the gear extension was completed, the indication of the status of the landing gear on the Landing Gear Control Panel, according to the crew witness, showed abnormal situation: Red Right Main Gear (RMLG) Light On, indicating RMLG not down and locked and Amber Right Main Gear Door (RMLGD) Light ON, indicating RMLGD not closed. A go around was initiated and Landing Gear selected Up. After Landing Gear Up selection Amber RMLGD light and Red RMLG Light were remaining ON. The crew made a decision to fly to Vilnius (EYVI). During this time passengers were briefed about the situation and reseated away from the propellers. Prior to land at Vilnius Airport, landing gear alternate extension was performed, but unsafe position of RMLG was still indicated. On final approach to Vilnius, the right engine was feathered. Landing was performed on the left side of the runway. Shortly after touchdown the RMLG collapsed. The left engine was shut down. The aircraft rolled off the runway and came to a stand about 40 m to the right at 1150 m distance from the threshold. The aircraft was substantially damaged, no injuries were reported.

## Findings

The examination of the Right Main Landing Gear showed separation of the retraction actuator rod end from its piston rod and two broken hinge lugs of the forward stabilizer brace assembly (see Appendix, Figure 1, Figure 2).

The examination of the piston rod and rod end in the laboratory indicated that the threaded connection between retraction actuator piston rod and rod end had suffered corrosion. Deterioration of the threads resulted in separation of the connection.

The examination of the fracture surfaces of the broken forward stabilizer hinge lugs revealed that the fractures were fresh, without any sign of previous cracks. It seems that the disintegration of the stabilizer was secondary damage caused by the separation of the actuator rod.

## Recommendations

Transport Canada, the regulatory authority of the state of manufacturer, has issued an emergency Airworthiness Directive for all DHC-8-400 operators concerning further operation of this type of aircraft.

The investigation is ongoing.

## Appendix



Figure 1: View of separated rod end.





Figure 2: View of broken stabilizer brace assembly.



## **Bilag 13**



## Bombardier Q400

### All Operator Message No. 238

---

---

ATTN: Director/Manager of: Maintenance  
Engineering  
Quality Control  
Flight Operations  
Procurement/Spares

DATE: 12 Sep 07

ATA: 3210 MODEL: Q400

SUBJECT: Transport Canada Airworthiness Directive CF-2007-20 Issued Against  
DHC-8-400 Main Landing Gear

REFERENCE: /A/ AOM 235, In-service Incident – Right Main Landing Gear Collapse After  
Landing  
/B/ AOM 236A, Update - In-service Incident – Right Main Landing Gear  
Collapse After Landing  
/C/ AOM 237 In-service Incident – Second Occurrence of Right Main Landing  
Gear Collapse After Landing

The following message is being sent to all Bombardier Q400 Operators and Bombardier Regional Aircraft Field Service Representatives.

This message contains information requiring attention and/or action. Please ensure timely and appropriate distribution within maintenance and flight operations departments.

---

---

#### DISCUSSION:

Transport Canada has recently issued Airworthiness Directive (AD) No. CF-2007-20. A copy of the AD follows, and is provided to all Bombardier Q400 Operators, as advisory information only.

Please direct responses and inquiries to the Technical Help Desk in Toronto at telephone (416) 375-4000 or facsimile (416) 375-4539 or e-mail: [thd.qseries@aero.bombardier.com](mailto:thd.qseries@aero.bombardier.com)

Michel Babin, Manager, In-Service Engineering Systems and Martin Elliott, Director, In-Service Engineering & Technical Support, Bombardier Regional Aircraft.



No.	1/2
<b>CF-2007-20</b>	
Issue Date	
<b>12 September 2007</b>	

# AIRWORTHINESS DIRECTIVE

The following airworthiness directive (AD) may be applicable to an aircraft which our records indicate is registered in your name. ADs are issued pursuant to **Canadian Aviation Regulation (CAR) 593**. Pursuant to **CAR 605.84** and the further details of **CAR Standard 625, Appendix H**, the continuing airworthiness of a Canadian registered aircraft is contingent upon compliance with all applicable ADs. Failure to comply with the requirements of an AD may invalidate the flight authorization of the aircraft. Alternative means of compliance shall be applied for in accordance with **CAR 605.84** and the above-referenced **Standard**.  
 This AD has been issued by the Continuing Airworthiness Division (AARDG), Aircraft Certification Branch, Transport Canada, Ottawa, telephone 613 952-4357.

**URGENT URGENT URGENT URGENT URGENT URGENT URGENT URGENT URGENT**

## TRANSPORT CANADA EMERGENCY AIRWORTHINESS DIRECTIVE

**PLEASE FORWARD IMMEDIATELY TO THE PERSON RESPONSIBLE FOR THE OPERATION AND MAINTENANCE OF YOUR AIRCRAFT**

**Number:** CF--2007-20

**Subject:** DHC-8-400 Main Landing Gear

**Effective:** Immediately upon received.

**Applicability:** Bombardier Inc. DHC-8 aircraft, Models 400, 401 and 402, serial numbers 003 and subsequent.

**Compliance:** As indicated below.

**Background:** Two recent cases of main landing gear collapse have been reported. Main landing gear collapse may result in unsafe landing of the aircraft.

**Corrective Actions:** **A. General Visual Inspection of the Main Landing Gear System:**

For all aircraft, before further flight, perform a general visual inspection of the left hand and right hand main landing gear system in accordance with Bombardier DHC-8 Series 400 Maintenance Requirements Manual (PSM 1-84-7), Part 1 (Maintenance Review Board Report), tasks Z700-03E (left hand) and Z700-04E (right hand). Rectify any discrepancy found prior to further flight.

**B. General Visual Inspection of the Main Landing Gear Retract Actuator Jam Nut:**

For all aircraft, before further flight, perform a general visual inspection of the left hand and right hand main landing gear retract actuator jam nut to ensure the wire lock is in place and the nut is secured. If the wire lock is not in place or the jam nut is not secured, accomplish Bombardier Repair Drawing (RD) 8/4-32-059 prior to further flight.

**C. Detailed Visual Inspection of the Main Landing Gear Retract Actuator:**

1. For aircraft main landing gear retract actuator (p/n 46550-7 or 46550-9) that have accumulated 8,000 or more landings or in service for more than 4 years since new, whichever occurs first, perform detailed visual inspection in

Pursuant to **CAR 202.51** the registered owner of a Canadian aircraft shall, within seven days, notify the Minister in writing of any change of his or her name or address.

To request a change of address, contact the **Civil Aviation Communications Centre (AARC)** at **Place de Ville, Ottawa, Ontario K1A 0N8**, or **1-800-305-2059**, or [www.tc.gc.ca/civilaviation/communications/centre/address.asp](http://www.tc.gc.ca/civilaviation/communications/centre/address.asp)



accordance with Bombardier RD 8/4-32-059 before further flight.

2. For aircraft main landing gear retract actuator (p/n 46550-7 or 46550-9) that have accumulated between 4,000 to 7,999 landings or in service between 2 to 4 years since new, whichever occurs first, perform detailed visual inspection in accordance with RD 8/4-32-059 within 500 flight hours after the effective date of this directive.

**D. Reporting Requirement:**

Within 7 days after each inspection, report any discrepancies found during any of the above inspections to Bombardier Technical Help Desk.

**E. Ferry Flight:**

To permit the ferry of an aircraft to a location where the inspection requirements of this directive can be accomplished, adhere to the following procedures and limitations:

**Flight Crew Limitations and Procedures:**

1. Ferry Flight with gear extended and pinned.
2. Landing to be conducted at a minimum descent rate.
3. Minimize braking on landing.
4. Flight to be conducted per Aircraft Operating Manual (AOM) Section 4.8.
5. Essential crew only on board.
6. Flight in known or forecast icing condition is prohibited.

**Maintenance Procedures:**

1. Inspect the left hand and right hand main landing gear retract actuator jam nut to ensure the wire lock is in place and the nut is secure.
2. Perform the general visual inspections as defined in accordance with Bombardier All Operators Message No. 236 Rev A or later revisions.
3. If items 1 and 2 results are satisfactory, insert main landing gear ground lock pins and lockwire in place.
4. Ensure the nose landing gear ground lock is engaged.

**Authorization:** For Minister of Transport, Infrastructure and Communities

B. Goyaniuk  
Chief, Continuing Airworthiness

**Contact:** Mr. Anthony Wan, Continuing Airworthiness, Ottawa, telephone 613-952-4410, facsimile 613-996-9178 or e-mail wana@tc.gc.ca or any Transport Canada Centre.





## **Bilag 14**



## Bombardier Q400

### All Operator Message No. 239

---

---

ATTN: Director/Manager of: Maintenance  
Engineering  
Quality Control  
Flight Operations  
Procurement/Spares

DATE: 12 Sep 07

ATA: 3210 MODEL: Q400

SUBJECT: RD 8/4-32-059 Revision 1 for Transport Canada AD CF-2007-20 Issued Against  
DHC-8-400 Main Landing Gear

REFERENCE: /A/ AOM 235, In-service Incident – Right Main Landing Gear Collapse After  
Landing  
/B/ AOM 236A, Update - In-service Incident – Right Main Landing Gear  
Collapse After Landing  
/C/ AOM 237, In-service Incident – Second Occurrence of Right Main Landing  
Gear Collapse After Landing  
/D/ AOM 238, Transport Canada Airworthiness Directive (AD) CF-2007-20  
Issued Against DHC-8-400 Main Landing Gear

The following message is being sent to all Bombardier Q400 Operators and Bombardier Regional Aircraft Field Service Representatives.

This message contains information requiring attention and/or action. Please ensure timely and appropriate distribution within maintenance and flight operations departments.

---

---

#### DISCUSSION:

This AOM is being issued to inform Operators of the release of Repair Drawing (RD) 8/4-32-059 Issue 1 required for initial compliance to Transport Canada Airworthiness Directive (AD) No. CF-2007-20.

Issue 1 of the RD provides inspection and return to service instructions for actuator piston rods with no damage or corrosion. Issue 2 of the RD will contain corrosion, damage limits and

applicable repair procedures. Issue 2, is expected to be released on Thursday, 13 Sep 2007 (GMT -5) after it has received Transport Canada approval.

Tooling is required for the replacement of the rod end of the actuator. Tooling is expected to be available by close of normal business, Thursday, 13 Sep 2007 (GMT -5). Operators are requested to send No Charge Purchase Orders to Goodrich for tooling, as detailed below.

Goodrich Tool Number P/N CG-56806

Goodrich Contact:

David Jacobsen: Email: [david.jacobsen@goodrich.com](mailto:david.jacobsen@goodrich.com)

Phone: 905-825-1515 x 3408

Fax: 905-825-1582

Please direct responses and inquiries to the Technical Help Desk in Toronto at telephone (416) 375-4000 or facsimile (416) 375-4539 or e-mail: [thd.qseries@aero.bombardier.com](mailto:thd.qseries@aero.bombardier.com)

Alisa Turk, Manager, Technical Help Desk and Martin Elliott, Director, In-Service Engineering & Technical Support, Bombardier Regional Aircraft.

# **Bilag 15**



## Bombardier Q400

### All Operator Message No. 240

---

---

ATTN: Director/Manager of: Maintenance  
Engineering  
Quality Control  
Flight Operations  
Procurement/Spares

DATE: 13 Sep 07

ATA: 3210 MODEL: Q400

SUBJECT: RD 8/4-32-059 Revision 2 for Transport Canada AD CF-2007-20 Issued Against  
DHC-8-400 Main Landing Gear

REFERENCE: /A/ AOM 235, In-service Incident – Right Main Landing Gear Collapse After  
Landing  
/B/ AOM 236A, Update - In-service Incident – Right Main Landing Gear  
Collapse After Landing  
/C/ AOM 237, In-service Incident – Second Occurrence of Right Main Landing  
Gear Collapse After Landing  
/D/ AOM 238, Transport Canada Airworthiness Directive (AD) CF-2007-20  
Issued Against DHC-8-400 Main Landing Gear  
/E/ AOM 239 RD 8/4-32-059 Revision 1 for Transport Canada AD CF-2007-20  
Issued Against DHC-8-400 Main Landing Gear

The following message is being sent to all Bombardier Q400 Operators and Bombardier Regional Aircraft Field Service Representatives.

This message contains information requiring attention and/or action. Please ensure timely and appropriate distribution within maintenance and flight operations departments.

---

---

#### DISCUSSION:

This AOM is being issued to inform Operators of the release of Repair Drawing (RD) 8/4-32-059 Issue 2 required for compliance to Transport Canada Airworthiness Directive (AD) No. CF-2007-20.

Issue 2 of RD 8/4-32-059 contains damage limits and a repair procedure for the Main Landing Gear retraction actuator piston that has been approved by Transport Canada. Issue 2 has been attached. Salvage drawing S2116 will be released shortly.

Operators having complied with Issue 1 of RD 8/4-32-059 with no findings are not required to repeat the inspections specified in Issue 2.

Please direct responses and inquiries to the Technical Help Desk in Toronto at telephone (416) 375-4000 or facsimile (416) 375-4539 or e-mail: [thd.qseries@aero.bombardier.com](mailto:thd.qseries@aero.bombardier.com)

Alisa Turk, Manager, Technical Help Desk and Martin Elliott, Director, In-Service Engineering & Technical Support, Bombardier Regional Aircraft.



## **Bilag 16**



## Bombardier Q400

### All Operator Message No. 241A

---

ATTN: Director/Manager of: Maintenance  
Engineering  
Quality Control  
Flight Operations  
Procurement/Spares

DATE: 14 Sep 07

ATA: 3210 MODEL: Q400

SUBJECT: RD 8/4-32-059 Revision 3 for Transport Canada AD CF-2007-20 Issued Against DHC-8-400 Main Landing Gear

REFERENCE: /A/ AOM 235, In-service Incident – Right Main Landing Gear Collapse After Landing  
/B/ AOM 236A, Update - In-service Incident – Right Main Landing Gear Collapse After Landing  
/C/ AOM 237, In-service Incident – Second Occurrence of Right Main Landing Gear Collapse After Landing  
/D/ AOM 238, Transport Canada Airworthiness Directive (AD) CF-2007-20 Issued Against DHC-8-400 Main Landing Gear  
/E/ AOM 239 RD 8/4-32-059 Revision 1 for Transport Canada AD CF-2007-20 Issued Against DHC-8-400 Main Landing Gear  
/E/ AOM 240 RD 8/4-32-059 Revision 2 for Transport Canada AD CF-2007-20 Issued Against DHC-8-400 Main Landing Gear

The following message is being sent to all Bombardier Q400 Operators and Bombardier Regional Aircraft Field Service Representatives.

This message contains information requiring attention and/or action. Please ensure timely and appropriate distribution within maintenance and flight operations departments.

---

## **DISCUSSION:**

This AOM is being issued to inform Operators of the release of Repair Drawing (RD) 8/4-32-059 Issue 3 required for compliance to Transport Canada Airworthiness Directive (AD) No. CF-2007-20.

Issue 3 of RD 8/4-32-059 contains a temporary repair procedure for the Main Landing Gear retraction actuator piston utilizing a dowel pin solution. Issue 3 has been attached.

Purchase orders for the pins are to be submitted to Goodrich Landing Gear.

Operators having complied with Issue 1 of RD 8/4-32-059 with no findings are not required to repeat the inspections specified in Issue 2 or Issue 3.

Please direct responses and inquiries to the Technical Help Desk in Toronto at telephone (416) 375-4000 or facsimile (416) 375-4539 or e-mail: [thd.qseries@aero.bombardier.com](mailto:thd.qseries@aero.bombardier.com)

Alisa Turk, Manager, Technical Help Desk and Martin Elliott, Director, In-Service Engineering & Technical Support, Bombardier Regional Aircraft.

Rev A: Added clarification for Operators having complied with Issue 1 of RD.

## **Bilag 17**



## Bombardier Q400

### All Operator Message No. 242B

---

ATTN: Director/Manager of: Maintenance  
Engineering  
Quality Control  
Flight Operations  
Procurement/Spares

DATE: 19 Sep 2007

ATA: 3210 MODEL: Q400

SUBJECT: Purchasing information for AD CF-2007-20 related spare parts

REFERENCE: /A/ AOM 238, Transport Canada Airworthiness Directive (AD) CF-2007-20  
Issued Against DHC-8-400 Main Landing Gear  
/B/ AOM 241A, RD 8/4-32-059 Revision 3 for Transport Canada AD  
CF-2007-20 Issued Against DHC-8-400 Main Landing Gear

The following message is being sent to all Bombardier Aerospace Regional Aircraft Q400 Operators and Bombardier Aerospace Regional Aircraft Field Service Representatives.

This message contains information requiring attention and/or action. Please ensure timely and appropriate distribution within maintenance and purchasing departments.

---

#### DISCUSSION:

This AOM is being issued to advise Operators where to procure parts associated with Transport Canada Airworthiness Directive (AD) No CF-2007-20, and Repair Drawing (RD) 8/4 32-059.

The following parts are to be procured through Bombardier Aerospace AOG:

<u>Description</u>	<u>Part Number(s)</u>
Assembly, Rod End	P3A2750
Retraction Actuator Assembly MLG	46550-9
Piston (PRFD)	46570-3
Scraper	R2301-220S041
Seal, Dynamic Rod	7220FT-954-P4
Seal, Static Piston Head	7145MT-954-P4

<u>Description</u>	<u>Part Number(s)</u>
Nut Gland	46572-5
Nut, Jam	NAS509-14
Seal, Dynamic, Piston Head	7332MT-954-P4
Nut, Jam	NAS1423-14
Nut, Jam	46563-3
Ring, Damper	46571-3
Locking Device	NAS1193K14CP (for aircraft post SB 84-32-35)

Please forward your Purchase Orders to:  
Bombardier AOG  
Fax: (416) 375 3231  
Tel: (416) 375 3910  
E-mail: [aog@aero.bombardier.com](mailto:aog@aero.bombardier.com)

The following parts are to be procured through Goodrich Landing Gear:

<u>Description</u>	<u>Part Number(s)</u>
Pin	S2117-101
Helicoil	MS124704
Tap	STI7814H3P (Goodrich approved alternate PN 8193-14)
Insertion Tool	HIT7814 (Goodrich approved alternate PN 535-14)
Inspection Tool	CG-56806

Please forward your Purchase Orders to:  
David Jacobsen  
Fax: (905) 825 1583  
Tel: (905) 825 1515 x 3408  
E- Email: [david.jacobsen@goodrich.com](mailto:david.jacobsen@goodrich.com)

Please direct responses and inquiries to Bombardier Aerospace Regional Aircraft Field Service Representative or the Spares AOG Desk in Toronto at telephone (416) 375-3910 or facsimile (416) 375-3231 or e-mail: [aog@aero.bombardier.com](mailto:aog@aero.bombardier.com)

Bill Molloy, Director, Customer Services, and Martin Elliott, Director, In-Service Engineering & Technical Support, Bombardier Aerospace Regional Aircraft.

Rev A - PN typos and description of PN's corrected to reflect CMM nomenclature description  
Rev B – Added Goodrich approved alternate part numbers for tap and insertion tool



## **Bilag 18**



# BOMBARDIER

## REPAIR DRAWING (RD)

1 TITLE Inspection procedure for retraction actuators p/n 46550-7 or 46550-9 rod end.		2 RD NUMBER 8/4-32-059	
		3 SECTION 1	4 SHEET 1
6 PRIME DESIGN ACTIVITY BOMBARDIER INC., DOWNSVIEW 71867	6 ADDITIONAL LIMITATIONS NONE	7 SERIES DHC-8-400	8 APPLICABILITY Models 400, 401 and 402

9 DESCRIPTION

This RD defines an inspection procedure for retraction actuators p/n 46550-7 or 46550-9 rod end. (2)

This RD is to be accomplished in conjunction with Goodrich SCR 086-07 rev. ~~NC~~ A. (2)

The procedure involves removing the rod end of the retraction actuator assembly in accordance with SCR 086-07 rev. ~~NC~~ and inspecting affected parts for any signs of corrosion or wear. (2)

No corrosion or wear damage is allowed, *EXCEPT AS PERMITTED IN SCR 086-07 REV.* (2)

Provided the components are free of any damage re-assemble retraction actuator in accordance with SCR 086-07 rev. ~~NC~~ A. (2)

The details of this procedure are covered by RD 8/4-32-059 section 1.

Sheet 1 Issue X 2  
Sheet 2 Issue X 2

*AT ISS. 2: SCR REF CHANGED TO REV. A, WAS REV. NC*

10 ISSUE	1	2			
11 DATE	12-Sep-07	13-SEP-07			
12 PREPARED BY	A. Vinitsky	A. VINITSKY			
13 STRESS	N/A	<i>[Signature]</i>			
16 DESIGN AUTHORITY	M. BABIN <i>[Signature]</i>	M. BABIN <i>[Signature]</i>			
14	N/A				
15	N/A				
17 DAO AUTHORITY	14 Sept 2007	<i>[Signature]</i> 13/09/07			

18  THE TECHNICAL CONTENT OF THIS DOCUMENT IS APPROVED UNDER THE DESIGN AUTHORITY OF TRANSPORT CANADA DESIGN APPROVAL ORGANIZATION DAO NO. 98-11-02  BA ENGINEERING DISPOSITION FOR APPROVAL BY OPERATOR'S LOCAL AIRWORTHINESS AUTHORITY

THIS REPAIR DRAWING HAS BEEN PREPARED ON THE BASIS OF INFORMATION SUPPLIED TO BOMBARDIER INC. BY THE OPERATOR OR HIS AGENT. IT IS THE RESPONSIBILITY OF THE OPERATOR OR HIS AGENT TO VERIFY THAT THE INFORMATION SUPPLIED IS COMPLETE AND ACCURATE. BOMBARDIER INC. DOES NOT ACCEPT RESPONSIBILITY FOR ANY CONSEQUENCE RESULTING FROM INCOMPLETE OR INACCURATE REPORTING OF THE DAMAGE/DISCREPANCY.

THE INFORMATION, TECHNICAL DATA AND DESIGNS DISCLOSED HEREIN ARE THE EXCLUSIVE PROPERTY OF BOMBARDIER INC. OR CONTAIN PROPRIETARY RIGHTS OF OTHERS AND ARE NOT TO BE USED OR DISCLOSED TO OTHERS WITHOUT THE WRITTEN CONSENT OF BOMBARDIER INC. THE RECIPIENT OF THIS DOCUMENT, BY ITS RETENTION AND USE AGREES TO HOLD IN CONFIDENCE THE TECHNICAL DATA AND DESIGNS CONTAINED HEREIN. THE FOREGOING SHALL NOT APPLY TO PERSONS HAVING PROPRIETARY RIGHTS TO SUCH INFORMATION, TECHNICAL DATA OR SUCH DESIGNS TO THE EXTENT THAT SUCH RIGHTS EXIST.

10 ISSUE	1	2			2 RD NUMBER	3 SECTION	4 SHEET
					8/4-32-059	1	2

Retraction actuator assembly p/n 46550-7/-9

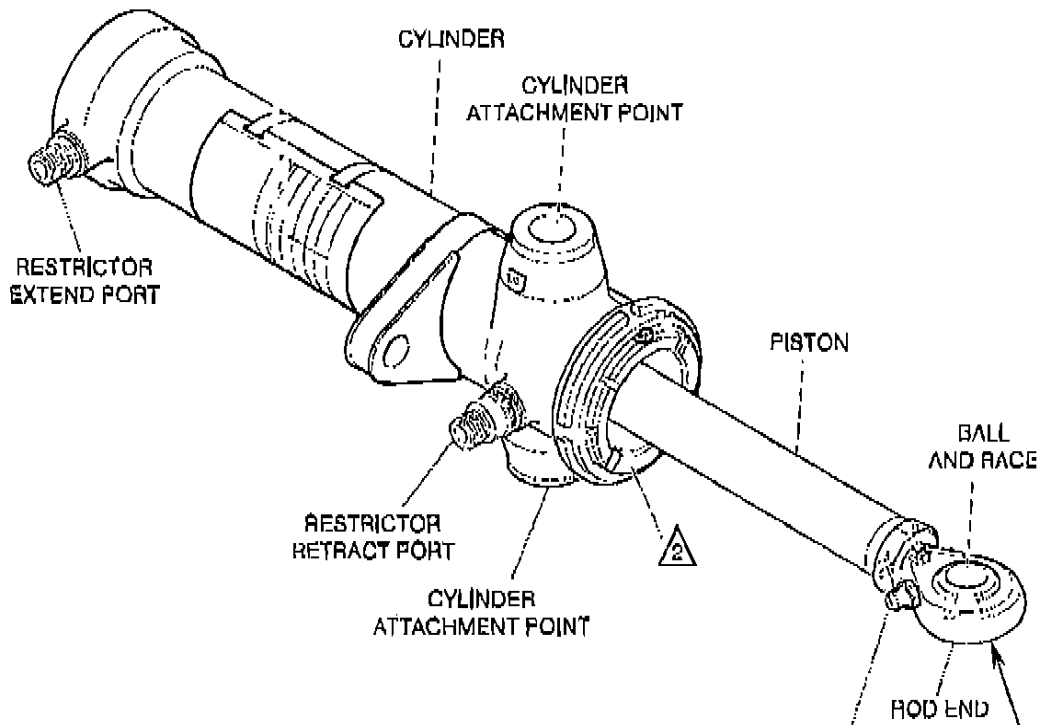

Remove the rod end of the retraction actuator assembly in accordance with SCR 086-07 rev. ~~REV. A.~~

Inspect affected parts for any signs of corrosion or wear.

②

No corrosion or wear damage is allowed, *EXCEPT AS NOTED IN SCR 086-07 REV. A.* Provided the components are free of any damage re-assemble retraction actuator in accordance with SCR 086-07 rev. ~~REV. A.~~

## **Bilag 19**



# BOMBARDIER

## REPAIR DRAWING (RD)

1 TITLE Inspection procedure for retraction actuators p/n 46550-7 or 46550-9 rod end.			2 RD NUMBER 8/4-32-059	
			3 SECTION 1	4 SHEET 1
6 PRIME DESIGN ACTIVITY BOMBARDIER INC., DOWNSVIEW 71867	6 ADDITIONAL LIMITATIONS NONE	7 SERIES DHC-8-400	8 APPLICABILITY Models 400, 401 and 402	

9 DESCRIPTION

This RD defines an inspection procedure for retraction actuators p/n 46550-7 or 46550-9 rod end.

This RD is to be accomplished in conjunction with Goodrich SCR 086-07 rev. ~~HE~~ <sup>(2) (3)</sup> A, B

The procedure involves removing the rod end of the retraction actuator assembly in accordance with SCR 086-07 rev. ~~HE~~ <sup>(2)</sup> and inspecting affected parts for any signs of corrosion or wear.

No corrosion or wear damage is allowed, <sup>(2)</sup> ~~EXCEPT AS PERMITTED IN SCR 086-07 REV. B~~ <sup>(3)</sup>

Provided the components are free of any damage re-assemble retraction actuator in accordance with SCR 086-07 rev. ~~HE~~ <sup>(2) (3)</sup> A, B

The details of this procedure are covered by RD 8/4-32-059 section 1.

Sheet 1 Issue ~~1~~ <sup>2</sup> 3  
Sheet 2 Issue ~~1~~ <sup>2</sup> 3

AT ISS. 2: SCR REF CHANGED TO REV. A, WAS REV. NG

10 ISSUE	1	2	3
11 DATE	12-Sep-07	13-SEP-07	13-SEP-07
12 PREPARED BY	A. Vinitsky	A. VINITSKY	A. TURK
13 STRESS	N/A	<i>[Signature]</i>	<i>[Signature]</i>
16 DESIGN AUTHORITY	M. BABIN <i>[Signature]</i>	M. BABIN <i>[Signature]</i>	M. BABIN <i>[Signature]</i>
14	N/A		
15	N/A		
17 DAO AUTHORITY	14 Sept 2007 <i>[Signature]</i>	<i>[Signature]</i> 13/9/07	<i>[Signature]</i> 14/9/07

18  THE TECHNICAL CONTENT OF THIS DOCUMENT IS APPROVED UNDER THE DESIGN AUTHORITY OF TRANSPORT CANADA DESIGN APPROVAL ORGANIZATION DAO NO. 85-11-02  BA ENGINEERING DISPOSITION FOR APPROVAL BY OPERATOR'S LOCAL AIRWORTHINESS AUTHORITY

THIS REPAIR DRAWING HAS BEEN PREPARED ON THE BASIS OF INFORMATION SUPPLIED TO BOMBARDIER INC. BY THE OPERATOR OR HIS AGENT. IT IS THE RESPONSIBILITY OF THE OPERATOR OR HIS AGENT TO VERIFY THAT THE INFORMATION SUPPLIED IS COMPLETE AND ACCURATE. BOMBARDIER INC. DOES NOT ACCEPT RESPONSIBILITY FOR ANY CONSEQUENCE RESULTING FROM INCOMPLETE OR INACCURATE REPORTING OF THE DAMAGE / DISCREPANCY.

THE INFORMATION, TECHNICAL DATA AND DESIGN DISCLOSED HEREIN ARE THE EXCLUSIVE PROPERTY OF BOMBARDIER INC. OR CONTAIN PROPRIETARY RIGHTS OF OTHERS AND ARE NOT TO BE USED OR DISCLOSED TO OTHERS WITHOUT THE WRITTEN CONSENT OF BOMBARDIER INC. THE RECIPIENT OF THIS DOCUMENT, BY ITS RETENTION AND USE AGREES TO HOLD IN CONDEMNATION THE TECHNICAL DATA AND DESIGNS CONTAINED HEREIN. THE FOREGOING SHALL NOT APPLY TO PERSONS HAVING PROPRIETARY RIGHTS TO SUCH INFORMATION, TECHNICAL DATA OR SUCH DESIGNS TO THE EXTENT THAT SUCH RIGHTS EXIST.

10 ISSUE	1	2	3	2 RD NUMBER	3 SECTION	4 SHEET
				8/4-32-059	1	2

Retraction actuator assembly p/n 46550-7/-9

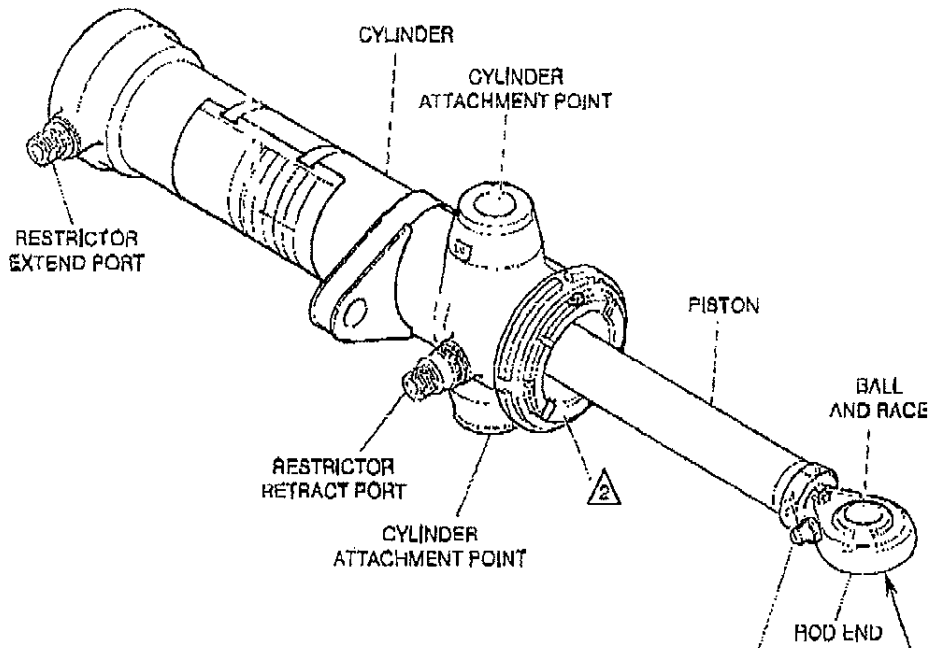

Remove the rod end of the retraction actuator assembly in accordance with SCR 086-07 rev. ~~A~~ B

Inspect affected parts for any signs of corrosion or wear.

②

③

No corrosion or wear damage is allowed, EXCEPT AS NOTED IN SCR 086-07 REV. ~~A~~ B  
 Provided the components are free of any damage re-assemble retraction actuator in accordance with SCR 086-07 rev. ~~A~~ B



## **Bilag 20**







## **Bilag 21**



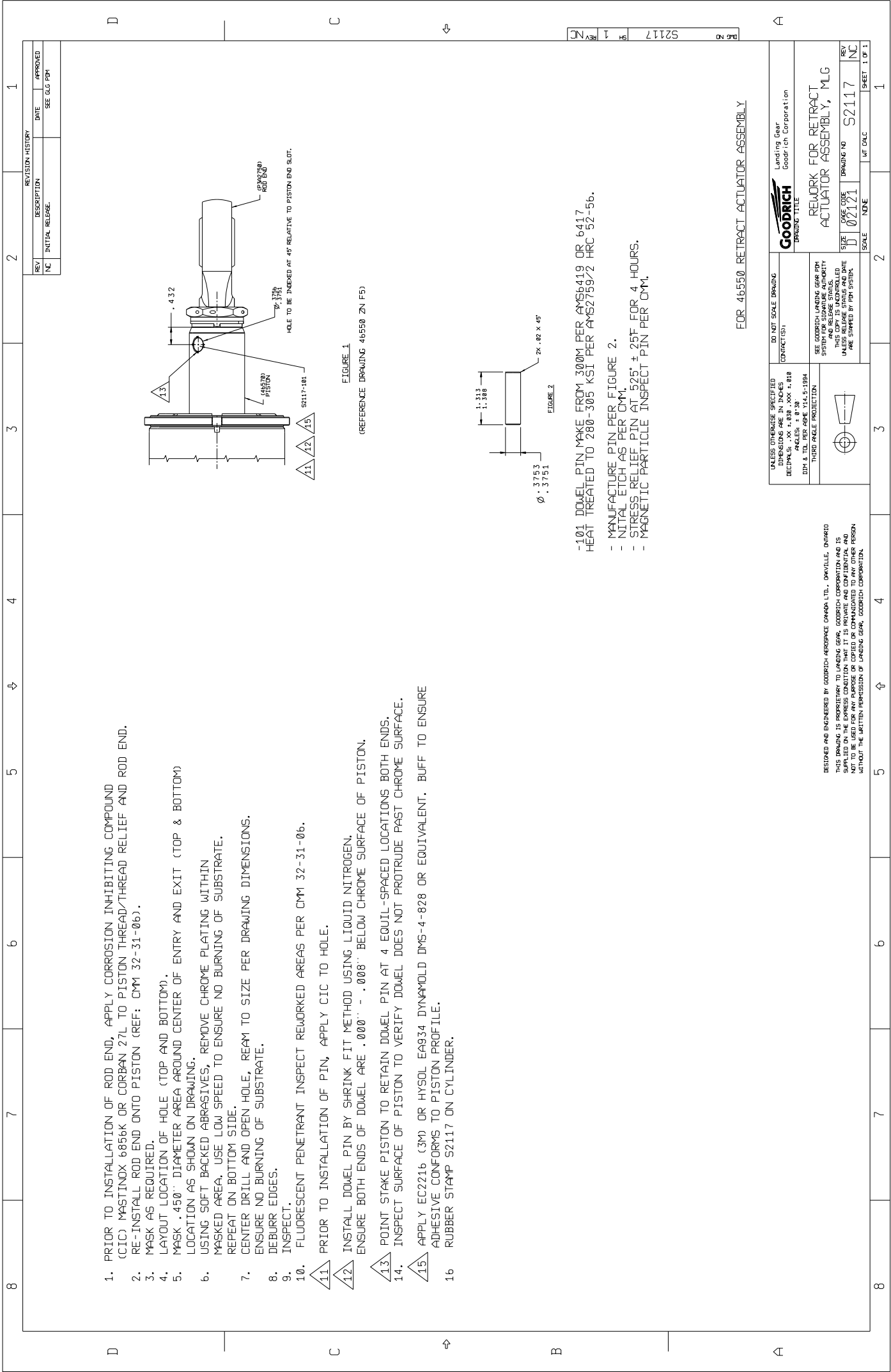













## **Bilag 22**

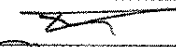

		<b>SERVICE CONCESSION REQUEST</b>			SCR NUMBER	REV	PROG
					SCR 086-07	A	2130
AIRCRAFT DETAILS					INDICATE IF <b>A.O.G.</b> >> <input checked="" type="checkbox"/> <<		
EVENT DATE (Y/M/D)	AIRLINE	A/C S/N	TSN	CSN			
ANY	ALL	4001 AND SUB					
ITEM	PART NO.	NAME			S/N	TSN	CSN
N.H.A ⇔							
N.H.A ⇔	46550-7/-9	RETRACTION ACTUATOR			ALL		
PART ⇔	46570-1/-3	PISTON			ALL		
<b>LIMITED FLIGHT REQUESTED</b> YES <input checked="" type="checkbox"/> NO <input type="checkbox"/> (IF YES, AUTHORIZED ENGINEER SIGNATURE REQUIRED)		REQUEST CATEGORY			AFFECTED SYSTEM		
		IN-SERVICE PROBLEM <input checked="" type="checkbox"/>			MLG <input checked="" type="checkbox"/>	BRAKING	<input type="checkbox"/>
INDICATE FC OR FH LIMITATION: <b>FC* 1000 OR 6 MONTHS</b> *WHICH EVER COMES FIRST		DISPOSITION SUMMARY NORMAL USE AFTER REPAIR <input checked="" type="checkbox"/> LIMITED SERVICE <input checked="" type="checkbox"/> TEMPORARY REPAIR <input type="checkbox"/> REMOVE & REPAIR <input checked="" type="checkbox"/> REPLACE PART <input checked="" type="checkbox"/>			NLG <input type="checkbox"/>	STEERING	<input type="checkbox"/>
IF ONLY FC IS SPECIFIED INDICATE FH NOT RELEVANT <input type="checkbox"/> OR SPECIFY LIMITATION IN TERMS OF AIRCRAFT CHECKS: A <input type="checkbox"/> C <input type="checkbox"/> L <input type="checkbox"/> x					PREVIOUS CONCESSIONS GRANTED FOR THIS SERIAL NUMBER COMPONENT		
SCR RAISED BY		B WEBER					

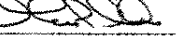
ITEM	PROBLEM DESCRIPTION
1	THERE HAVE BEEN 2 INSTANCES OF SEPARATION OF ROD END P/N P3A2750 AND PISTON P/N 46570-1/-3. INSPECTION OF THREAD CONDITION REQUIRED IN ACCORDANCE TO TRANSPORT CANADA AIRWORTHINESS DIRECTIVE (CF-2007-20).
REPORTED CAUSE OF PROBLEM:	
ADDITIONAL INFORMATION ATTACHED <input type="checkbox"/>	
>> SEE SHEET 2 AND SUBS FOR MORE INFORMATION <<	

		<b>SERVICE CONCESSION REQUEST</b>			SCR NUMBER	REV	PROG
					SCR 086-07		2130
AIRCRAFT DETAILS					INDICATE IF <b>A.O.G.</b> 		
EVENT DATE (Y/M/D)	AIRLINE	A/C S/N	TSN	CSN			
ANY	ALL	4001 AND SUB					
ITEM	PART NO.	NAME			S/N	TSN	CSN
N.H.A ⇨							
N.H.A ⇨	46550-7/-9	RETRACTION ACTUATOR			ALL		
PART ⇨	46570-1/-3	PISTON			ALL		
ITEM	CONTINUATION SHEET / INSTRUCTIONS						
1	<ol style="list-style-type: none"> <li>1. SHUT DOWN HYDRAULIC SYSTEM 2</li> <li>2. WITH ACTUATOR INSTALLED ON AIRCRAFT, REMOVE LOCK WIRE AND BACK OFF JAM NUT AS REQUIRED TO DISENGAGE LOCKING FEATURE.</li> <li>3. DISASSEMBLE AS REQUIRED, REMOVE ACTUATOR ROD END PIN (P/N 46160-1) FROM MAIN LANDING GEAR SHOCK STRUT ASSEMBLY</li> <li>4. FULLY COMPRESS PISTON</li> <li>5. SECURE PISTON, AND REMOVE ROD END FROM PISTON.</li> <li>6. IF ROD END (P/N P3A2750) DOES NOT EASILY BACK OUT OF PISTON WITHOUT BINDING AND WITH THE USE OF A STRAP WRENCH, REMOVE RETRACT ACTUATOR P/N 46550-7/-9 FROM GEAR ASSEMBLY.                             <ul style="list-style-type: none"> <li>- REPLACE WITH NEW OR REFURBISHED RETRACT ACTUATOR P/N 46550-7/-9 IN ACCORDANCE WITH BOMBARDIER AMM. REPLACEMENT ACTUATOR TO HAVE INCORPORATED CORROSION INHIBITING COMPOUND (CIC).</li> <li>- IF ACTUATOR DOES NOT HAVE CORROSION INHIBITING COMPOUND (CIC) WITHIN 500 FC OF INITIAL INSPECTION, INCORPORATED SEE <b>SECTION A</b> OF THIS SCR.</li> </ul> </li> <li>7. IF ROD END (P/N P3A2750) BACKS OUT OF PISTON WITHOUT BINDING, COMPLETELY REMOVE ROD END AND CONTINUE WITH OPERATIONS 8 THRU 16.</li> <li>8. WIRE BRUSH WITH SOLVENT TO CLEAN THREADED AREAS OF PISTON AND ROD.</li> <li>9. VISUALLY INSPECT ROD END (P/N P3A2750) FOR EVIDENCE OF CORROSION CONTAMINATION IN THREADS UNDER ADEQUATE LIGHTING CONDITIONS.                             <ul style="list-style-type: none"> <li>- IF ANY EVIDENCE OF PITTING CORROSION IS FOUND ON ROD END THEN DISCARD THE ROD END.</li> </ul> </li> </ol>						
DISPOSITION AUTHORIZATION							
	NAME (PRINT)	SIGNATURE	DATE(Y/M/D)	AUTHORIZED ENGINEER OR HIGHER ENGINEERING AUTHORITY    DATE: Sept 13, 2007			
ENGINEER	RAMAN MALIK		2007/09/13				
STRESS	A. NORTH		2007/09/13				
OTHER (SPECIFY)	M. PERRELLA		2007/09/13				
				Page 2 of 7			

		<b>SERVICE CONCESSION REQUEST</b>			SCR NUMBER	REV	PROG
					SCR 086-07	A	2130
AIRCRAFT DETAILS					INDICATE IF <b>A.O.G.</b> ➤ ➤ <input checked="" type="checkbox"/> ➤ ➤		
EVENT DATE (Y/M/D)	AIRLINE	A/C S/N	TSN	CSN			
ANY	ALL	4001 AND SUB					
ITEM	PART NO.	NAME			S/N	TSN	CSN
N.H.A ⇌							
N.H.A ⇌	46550-7/-9	RETRACTION ACTUATOR			ALL		
PART ⇌	46570-1/-3	PISTON			ALL		

**INSTRUCTIONS / CONTINUATION SHEET**

10. VISUALLY INSPECT PISTON (P/N 46570-1/-3) THREADS AND THREAD RELIEF AREA FOR EVIDENCE OF CORROSION AND/OR DAMAGE AND/OR PITTING (REF. FIGURE 1), USING A SMALL MIRROR UNDER ADEQUATE LIGHTING CONDITIONS. INSPECT WITH 10 X MAGNIFICATION MIRROR UNDER ADEQUATE LIGHTING CONDITIONS WITHIN **500 FC**
  - IF CORROSION IS FOUND IN THREADED AREA OF PISTON P/N 46570-1/-3 PERFORM REWORK IN ACCORDANCE WITH **SECTION B** OF THIS SCR
  - IF NO CORROSION IS FOUND CONTINUE WITH REMAINING OPERATIONS
11. COAT ACTUATOR THREADS AND THREAD RELIEF AS WELL AS ROD END THREADS, WITH CORROSION INHIBITING COMPOUND MASTINOX 6856K OR CORBAN 27L WITHIN 500 FC OF INITIAL INSPECTION.
12. RE-INSTALL ROD END AND JAM NUT INTO PISTON ASSY
13. DISASSEMBLE AS REQUIRED TO REMOVE ACTUATOR FROM YOKE ASSEMBLY (NOTE: HYDRAULIC DISCONNECTION NOT REQUIRED).
14. USING TOOL NUMBER CG 56806, ADJUST ROD END RETRACTED LENGTH AS REQUIRED, TORQUE JAM NUT TO 660-980 IN-LBS, SAFETY LOCK WIRE PER MS 33540,
  - OPTIONAL PROCEDURE FOR RIGGING ACTUATOR LENGTH: RIG ACTUATOR TO NOMINAL RETRACTED LENGTH PER TOOL DRAWING (REF DIM 4.286 INCH) AND TORQUE JAM NUT TO 660-980 IN-LBS, SAFETY LOCK WIRE PER MS33540.
  - NOTE: IF OPTIONAL PROCEDURE IS USED, GEAR SWINGS ARE REQUIRED (2 POWDERED CYCLES AND 1 ALTERNATE RELEASE TO VERIFY FUNCTIONAL CAPABILITY).
15. RE-INSTALL ACTUATOR ONTO YOKE ASSEMBLY.
16. EXTEND PISTON AND RE-ATTACH TO SHOCK STRUT ASSEMBLY USING PIN P/N 46160-1, AND TORQUE IN ACCORDANCE AMM REQUIREMENTS.

**DISPOSITION AUTHORIZATION**

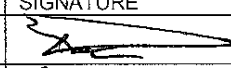
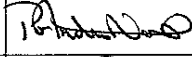
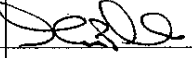
	NAME (PRINT)	SIGNATURE	DATE(Y/M/D)	AUTHORIZED ENGINEER OR HIGHER ENGINEERING AUTHORITY  DATE: Sept 13, 2007
ENGINEERING	RAMAN MALIK		2007/09/13	
STRESS	A. NORTH		2007/09/13	
OTHER (SPECIFY)	M. PERRELLA		2007/09/13	
				<b>Page 3 of 7</b>

		<b>SERVICE CONCESSION REQUEST</b>			SCR NUMBER	REV	PROG
					SCR 086-07	A	2130
AIRCRAFT DETAILS					INDICATE IF <b>A.O.G.</b> >>> <input checked="" type="checkbox"/> <<<		
EVENT DATE (Y/M/D)	AIRLINE	A/C S/N	TSN	CSN			
ANY	ALL	4001 AND SUB					
ITEM	PART NO.	NAME			S/N	TSN	CSN
N.H.A ⇨							
N.H.A ⇨	46550-7/-9	RETRACTION ACTUATOR			ALL		
PART ⇨	46570-1/-3	PISTON			ALL		

**INSTRUCTIONS / CONTINUATION SHEET**



**SECTION A – APPLICABLE TO EXISTING ACTUATORS ASSEMBLED WITHOUT CIC**

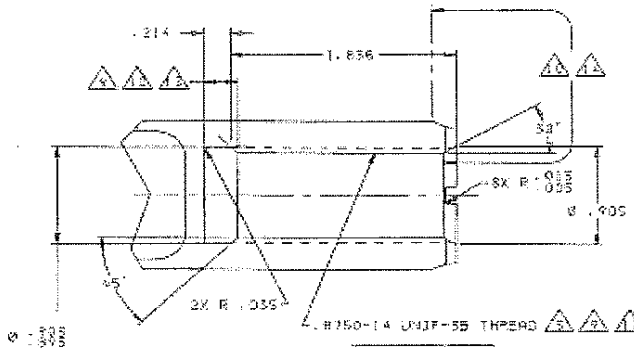

1. DISASSEMBLE AS REQUIRED TO REMOVE ROD END P/N P3A2750 FROM ACTUATOR ASSEMBLY.
2. INSPECT - ENSURE NO EVIDENCE OF CORROSION ON ACTUATOR PISTON THREADS OR ROD END THREADS.
3. COAT ACTUATOR THREADS AND THREAD RELIEF AS WELL AS ROD END THREADS, WITH CIC MASTINOX 6856K OR CORBAN 27L, AND RE-INSTALL ROD END ONTO ACTUATOR ASSEMBLY.
4. ADJUST ACTUATOR RETRACTED LENGTH USING TOOL CG 56806 REQUIREMENTS OR IN ACCORDANCE WITH CMM 32-31-06 REQUIREMENTS. OPTIONAL PROCEDURE PER STEP 13, ABOVE, IS ALSO ACCEPTABLE
5. TORQUE JAM NUT TO 660-980 IN-LBS AND SAFETY LOCKWIRE PER MS 33540.

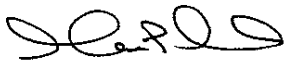

**FIGURE 1**

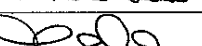
**DISPOSITION AUTHORIZATION**

ENGINEERING	NAME (PRINT) RAMAN MALIK	SIGNATURE 	DATE(Y/M/D) 2007/09/13	AUTHORIZED ENGINEER OR HIGHER ENGINEERING AUTHORITY    DATE: Sept 13, 2007
STRESS	A. NORTH		2007/09/13	
OTHER (SPECIFY)	M. PERRELLA		2007/09/13	
				<b>Page 4 of 7</b>

		<b>SERVICE CONCESSION REQUEST</b>			SCR NUMBER	REV	PROG
					SCR 086-07	A	2130
AIRCRAFT DETAILS					INDICATE IF <b>A.O.G.</b> 		
EVENT DATE (Y/M/D)	AIRLINE	A/C S/N	TSN	CSN			
ANY	ALL	4001 AND SUB					
ITEM	PART NO.	NAME			S/N	TSN	CSN
N.H.A ⇨							
N.H.A ⇨	46550-7/-9	RETRACTION ACTUATOR			ALL		
PART ⇨	46570-1/-3	PISTON			ALL		

**INSTRUCTIONS / CONTINUATION SHEET**

**SECTION B**

1. MASK AS REQUIRED TO PROTECT ACTUATOR HOUSING, GLAND AREA, AND EXPOSED CHROME OF PISTON FROM F.O.D CONTAMINATION AND DAMAGE DURING THE FOLLOWING REWORK.
2. CHASE PISTON THREADS AND THREAD RELIEF AREA TO REMOVE CORROSION PRODUCTS TO THE GREATEST POSSIBLE EXTENT USING THREAD COMB AND/OR STAINLESS STEEL WIRE BRUSH.
3. INSPECT THE ENTIRE PROFILE OF THREADS OVER THE FULL SPAN OF THREADS (REF. 1.836 DIM, FIGURE 1) AND THE RELIEF GROOVE IN PISTON USING SMALL MIRROR (10X MAGNIFICATION) UNDER ADEQUATE LIGHTING CONDITIONS.
4. **ACCEPTANCE CRITERIA**
  - A) LIGHT SURFACE CORROSION (NO PITTING) OVER THE ENTIRE THREADED LENGTH WITH AT LEAST FIVE CONSECUTIVE FULL UNDAMAGED THREADS WITHIN THE ENGAGED THREAD LENGTH (REF FIGURE 2) IS ACCEPTABLE FOR **1000 FC OR 6 MONTHS** (WHICH EVER OCCURS FIRST) OF CONTINUED SERVICE. RETRACT ACTUATOR TO BE INSPECTED TO ENSURE JAM NUT IS SECURE AND WIRE LOCK IS IN PLACE EVERY **100 FC**.
  - B) EVIDENCE OF MODERATE TO SEVERE PITTING CORROSION BEYOND CRITERIA STATED IN A). MUST BE REPAIRED PER SALVAGE DRAWING S2116 OR REPLACED.

**DISPOSITION AUTHORIZATION**

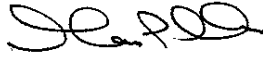
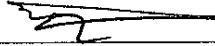
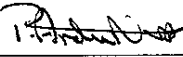
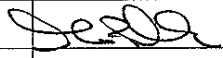
	NAME (PRINT)	SIGNATURE	DATE(Y/M/D)	AUTHORIZED ENGINEER OR HIGHER ENGINEERING AUTHORITY  DATE: Sept 13, 2007
ENGINEERING	RAMAN MALIK		2007/09/13	
STRESS	A. NORTH		2007/09/13	
OTHER (SPECIFY)	M. PERRELLA		2007/09/13	
				<b>Page 5 of 7</b>

		<b>SERVICE CONCESSION REQUEST</b>			SCR NUMBER	REV	PROG
					SCR 086-07	A	2130
AIRCRAFT DETAILS					INDICATE IF <b>A.O.G.</b> >>> <input checked="" type="checkbox"/> <<<		
EVENT DATE (Y/M/D)	AIRLINE	A/C S/N	TSN	CSN			
ANY	ALL	4001 AND SUB					
ITEM	PART NO.	NAME			S/N	TSN	CSN
N.H.A ⇨							
N.H.A ⇨	46550-7/-9	RETRACTION ACTUATOR			ALL		
PART ⇨	46570-1/-3	PISTON			ALL		

INSTRUCTIONS / CONTINUATION SHEET

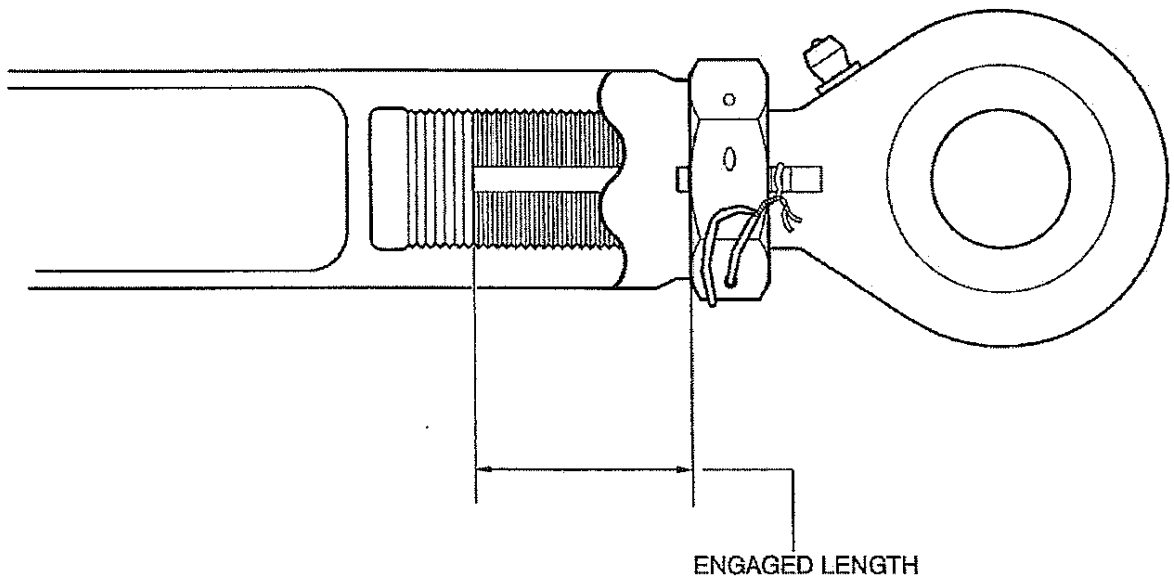

**FIGURE 2**

DISPOSITION AUTHORIZATION

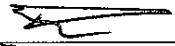
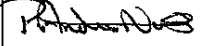
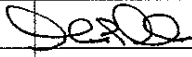
	NAME (PRINT)	SIGNATURE	DATE(Y/M/D)	AUTHORIZED ENGINEER OR HIGHER ENGINEERING AUTHORITY    DATE: Sept 13, 2007
ENGINEERING	RAMAN MALIK		2007/09/13	
STRESS	A. NORTH		2007/09/13	
OTHER (SPECIFY)	M. PERRELLA		2007/09/13	



		<b>SERVICE CONCESSION REQUEST</b>			SCR NUMBER	REV	PROG
					SCR 086-07	A	2130
<b>AIRCRAFT DETAILS</b>					INDICATE IF <b>A.O.G.</b> ➤ ➤ ☒ ☜ ☜		
EVENT DATE (Y/M/D)	AIRLINE	A/C S/N	TSN	CSN			
ANY	ALL	4001 AND SUB					
<b>ITEM</b>	<b>PART NO.</b>	<b>NAME</b>			<b>S/N</b>	<b>TSN</b>	<b>CSN</b>
N.H.A ⇄							
N.H.A ⇄	46550-7/-9	RETRACTION ACTUATOR			ALL		
PART ⇄	46570-1/-3	PISTON			ALL		

**INSTRUCTIONS / CONTINUATION SHEET**

SUGGESTED LIST OF CIC SUPPLIERS:

CORBAN 27L      <http://www.zipchem.com/locations.aspx>

MASTINOX 6856K      <http://www.ppg.com/prc-desoto/main.asp?img=crt&contLvl=mansites>

DEFINITIONS

SURFACE CORROSION : a uniform loss of metal due to corrosion

PITTING CORROSION : a localized attack which results in a depression or a pit

**DISPOSITION AUTHORIZATION**

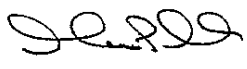
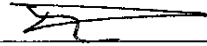
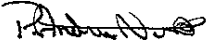
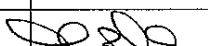
	NAME (PRINT)	SIGNATURE	DATE(Y/M/D)	AUTHORIZED ENGINEER OR HIGHER ENGINEERING AUTHORITY    DATE: Sept 13, 2007
ENGINEERING	RAMAN MALIK		2007/09/13	
STRESS	A. NORTH		2007/09/13	
OTHER (SPECIFY)	M. PERRELLA		2007/09/13	
				<b>Page 7 of 7</b>







## **Bilag 23**

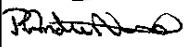

		<b>SERVICE CONCESSION REQUEST</b>			SCR NUMBER	REV	PROG
					SCR 086-07	B	2130
AIRCRAFT DETAILS					INDICATE IF <b>A.O.G.</b> >> <input checked="" type="checkbox"/> <<		
EVENT DATE (Y/M/D)	AIRLINE	A/C S/N	TSN	CSN			
ANY	ALL	4001 AND SUB					
ITEM	PART NO.	NAME			S/N	TSN	CSN
N.H.A ⇨							
N.H.A ⇨	46550-7/-9	RETRACTION ACTUATOR			ALL		
PART ⇨	46570-1/-3	PISTON			ALL		
<b>LIMITED FLIGHT REQUESTED</b> YES <input checked="" type="checkbox"/> NO <input type="checkbox"/> (IF YES, AUTHORIZED ENGINEER SIGNATURE REQUIRED)		REQUEST CATEGORY			AFFECTED SYSTEM		
		IN-SERVICE PROBLEM <input checked="" type="checkbox"/>			MLG <input checked="" type="checkbox"/>	BRAKING	<input type="checkbox"/>
INDICATE FC OR FH LIMITATION: <b>FC* 1000 OR 6 MONTHS</b> *WHICH EVER COMES FIRST		DISPOSITION SUMMARY NORMAL USE AFTER REPAIR <input checked="" type="checkbox"/> LIMITED SERVICE <input checked="" type="checkbox"/> TEMPORARY REPAIR <input type="checkbox"/> REMOVE & REPAIR <input checked="" type="checkbox"/> REPLACE PART <input checked="" type="checkbox"/>			NLG <input type="checkbox"/>	STEERING	<input type="checkbox"/>
IF ONLY FC IS SPECIFIED INDICATE FH NOT RELEVANT <input type="checkbox"/> OR SPECIFY LIMITATION IN TERMS OF AIRCRAFT CHECKS: A <input type="checkbox"/> C <input type="checkbox"/> L <input type="checkbox"/> x					PREVIOUS CONCESSIONS GRANTED FOR THIS SERIAL NUMBER COMPONENT		
SCR RAISED BY B WEBER					DATE RAISED 2007/09/12		

ITEM	PROBLEM DESCRIPTION
1	THERE HAVE BEEN 2 INSTANCES OF SEPARATION OF ROD END P/N P3A2750 AND PISTON P/N 46570-1/-3. INSPECTION OF THREAD CONDITION REQUIRED IN ACCORDANCE TO TRANSPORT CANADA AIRWORTHINESS DIRECTIVE (CF-2007-20).
REPORTED CAUSE OF PROBLEM:	
ADDITIONAL INFORMATION ATTACHED <input type="checkbox"/>	
>> SEE SHEET 2 AND SUBS FOR MORE INFORMATION <<	



		<b>SERVICE CONCESSION REQUEST</b>			SCR NUMBER SCR 086-07	REV B	PROG 2130
		AIRCRAFT DETAILS			INDICATE IF <b>A.O.G.</b> ➤➤ <input checked="" type="checkbox"/> ⬅️⬅️		
EVENT DATE (Y/M/D)	AIRLINE	A/C S/N	TSN	CSN			
ANY	ALL	4001 AND SUB					
<b>ITEM</b>	<b>PART NO.</b>	<b>NAME</b>		<b>S/N</b>	<b>TSN</b>	<b>CSN</b>	
N.H.A ⇨							
N.H.A ⇨	46550-7/-9	RETRACTION ACTUATOR		ALL			
PART ⇨	46570-1/-3	PISTON		ALL			
<b>ITEM</b>	<b>CONTINUATION SHEET / INSTRUCTIONS</b>						
1	<ol style="list-style-type: none"> <li>1. SHUT DOWN HYDRAULIC SYSTEM 2</li> <li>2. WITH ACTUATOR INSTALLED ON AIRCRAFT, REMOVE LOCK WIRE AND BACK OFF JAM NUT AS REQUIRED TO DISENGAGE LOCKING FEATURE.</li> <li>3. DISASSEMBLE AS REQUIRED, REMOVE ACTUATOR ROD END PIN (P/N 46160-1) FROM MAIN LANDING GEAR SHOCK STRUT ASSEMBLY</li> <li>4. FULLY COMPRESS PISTON</li> <li>5. SECURE PISTON, AND REMOVE ROD END FROM PISTON.</li> <li>6. IF ROD END (P/N P3A2750) DOES NOT EASILY BACK OUT OF PISTON WITHOUT BINDING AND WITH THE USE OF A STRAP WRENCH, REMOVE RETRACT ACTUATOR P/N 46550-7/-9 FROM GEAR ASSEMBLY.             <ul style="list-style-type: none"> <li>- REPLACE WITH NEW OR REFURBISHED RETRACT ACTUATOR P/N 46550-7/-9 IN ACCORDANCE WITH BOMBARDIER AMM. REPLACEMENT ACTUATOR TO HAVE INCORPORATED CORROSION INHIBITING COMPOUND (CIC).</li> <li>- IF ACTUATOR DOES NOT HAVE CORROSION INHIBITING COMPOUND (CIC) WITHIN 500 FC OF INITIAL INSPECTION, INCORPORATED SEE <b>SECTION A</b> OF THIS SCR.</li> </ul> </li> <li>7. IF ROD END (P/N P3A2750) BACKS OUT OF PISTON WITHOUT BINDING, COMPLETELY REMOVE ROD END AND CONTINUE WITH OPERATIONS 8 THRU 16.</li> <li>8. WIRE BRUSH WITH SOLVENT TO CLEAN THREADED AREAS OF PISTON AND ROD.</li> <li>9. VISUALLY INSPECT ROD END (P/N P3A2750) FOR EVIDENCE OF CORROSION CONTAMINATION IN THREADS UNDER ADEQUATE LIGHTING CONDITIONS.             <ul style="list-style-type: none"> <li>- IF ANY EVIDENCE OF PITTING CORROSION IS FOUND ON ROD END THEN DISCARD THE ROD END.</li> </ul> </li> </ol>						
<b>DISPOSITION AUTHORIZATION</b>							
	NAME (PRINT)	SIGNATURE	DATE(Y/M/D)	AUTHORIZED ENGINEER OR HIGHER ENGINEERING AUTHORITY   DATE: Sept 13, 2007			
ENGINEER	RAMAN MALIK		2007/09/13				
STRESS	A. NORTH		2007/09/13				
OTHER (SPECIFY)	M. PERRELLA		2007/09/13				
				<b>Page 2 of 7</b>			



		<b>SERVICE CONCESSION REQUEST</b>			SCR NUMBER SCR 086-07	REV B	PROG 2130
		AIRCRAFT DETAILS			INDICATE IF <b>A.O.G.</b> ➤➤ <input checked="" type="checkbox"/> ⬅️⬅️		
EVENT DATE (Y/M/D)	AIRLINE	A/C S/N	TSN	CSN			
ANY	ALL	4001 AND SUB					
ITEM	PART NO.	NAME		S/N	TSN	CSN	
N.H.A ⇨							
N.H.A ⇨	46550-7/-9	RETRACTION ACTUATOR		ALL			
PART ⇨	46570-1/-3	PISTON		ALL			

**INSTRUCTIONS / CONTINUATION SHEET**

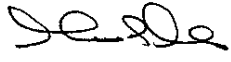
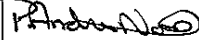
10. VISUALLY INSPECT PISTON (P/N 46570-1/-3) THREADS AND THREAD RELIEF AREA FOR EVIDENCE OF CORROSION AND/OR DAMAGE AND/OR PITTING (REF. FIGURE 1), USING A SMALL MIRROR UNDER ADEQUATE LIGHTING CONDITIONS. INSPECT WITH 10 X MAGNIFICATION MIRROR UNDER ADEQUATE LIGHTING CONDITIONS WITHIN **500 FC**
  - IF CORROSION IS FOUND IN THREADED AREA OF PISTON P/N 46570-1/-3 PERFORM REWORK IN ACCORDANCE WITH **SECTION B** OF THIS SCR
  - IF NO CORROSION IS FOUND CONTINUE WITH REMAINING OPERATIONS
11. COAT ACTUATOR THREADS AND THREAD RELIEF AS WELL AS ROD END THREADS, WITH CORROSION INHIBITING COMPOUND MASTINOX 6856K OR CORBAN 27L WITHIN 500 FC OF INITIAL INSPECTION.
12. RE-INSTALL ROD END AND JAM NUT INTO PISTON ASSY
13. DISASSEMBLE AS REQUIRED TO REMOVE ACTUATOR FROM YOKE ASSEMBLY (NOTE: HYDRAULIC DISCONNECTION NOT REQUIRED).
14. USING TOOL NUMBER CG 56806, ADJUST ROD END RETRACTED LENGTH AS REQUIRED, TORQUE JAM NUT TO 660-980 IN-LBS, SAFETY LOCK WIRE PER MS 33540. (FOR DOWEL PIN SOLUTION PER DRAWING S2117, PRIOR TO RIGGING THE ACTUATOR LUBRICATE THE PISTON IN AREA ADJACENT TO THE ROD END WITH SKYDROL)
  - OPTIONAL PROCEDURE FOR RIGGING ACTUATOR LENGTH: RIG ACTUATOR TO NOMINAL RETRACTED LENGTH PER TOOL DRAWING (REF DIM 4.286 INCH) AND TORQUE JAM NUT TO 660-980 IN-LBS, SAFETY LOCK WIRE PER MS33540.
  - NOTE: IF OPTIONAL PROCEDURE IS USED, GEAR SWINGS ARE REQUIRED (2 POWDERED CYCLES AND 1 ALTERNATE RELEASE TO VERIFY FUNCTIONAL CAPABILITY).
15. RE-INSTALL ACTUATOR ONTO YOKE ASSEMBLY.
16. EXTEND PISTON AND RE-ATTACH TO SHOCK STRUT ASSEMBLY USING PIN P/N 46160-1, AND TORQUE IN ACCORDANCE AMM REQUIREMENTS.

**DISPOSITION AUTHORIZATION**

	NAME (PRINT)	SIGNATURE	DATE(Y/M/D)	AUTHORIZED ENGINEER OR HIGHER ENGINEERING AUTHORITY
ENGINEERING	RAMAN MALIK		2007/09/13	 DATE: Sept 13, 2007
STRESS	A. NORTH		2007/09/13	
OTHER (SPECIFY)	M. PERRELLA		2007/09/13	
				<b>Page 3 of 7</b>

		<b>SERVICE CONCESSION REQUEST</b>			SCR NUMBER SCR 086-07	REV B	PROG 2130
		AIRCRAFT DETAILS			INDICATE IF <b>A.O.G.</b> 		
EVENT DATE (Y/M/D)	AIRLINE	A/C S/N	TSN	CSN			
ANY	ALL	4001 AND SUB					
ITEM	PART NO.	NAME		S/N	TSN	CSN	
N.H.A ⇨							
N.H.A ⇨	46550-7/-9	RETRACTION ACTUATOR		ALL			
PART ⇨	46570-1/-3	PISTON		ALL			

**INSTRUCTIONS / CONTINUATION SHEET**

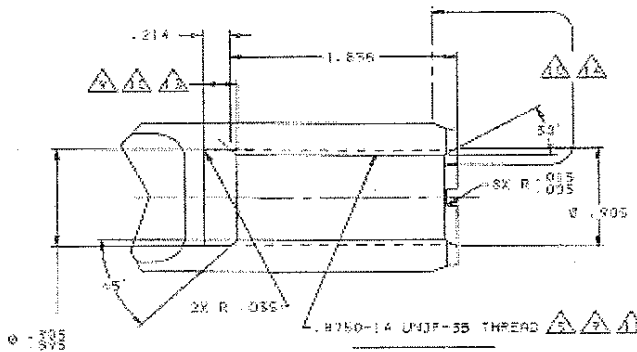

**SECTION A – APPLICABLE TO EXISTING ACTUATORS ASSEMBLED WITHOUT CIC**

1. DISASSEMBLE AS REQUIRED TO REMOVE ROD END P/N P3A2750 FROM ACTUATOR ASSEMBLY.
2. INSPECT - ENSURE NO EVIDENCE OF CORROSION ON ACTUATOR PISTON THREADS OR ROD END THREADS.
3. COAT ACTUATOR THREADS AND THREAD RELIEF AS WELL AS ROD END THREADS, WITH CIC MASTINOX 6856K OR CORBAN 27L, AND RE-INSTALL ROD END ONTO ACTUATOR ASSEMBLY.
4. ADJUST ACTUATOR RETRACTED LENGTH USING TOOL CG 56806 REQUIREMENTS OR IN ACCORDANCE WITH CMM 32-31-06 REQUIREMENTS. OPTIONAL PROCEDURE PER STEP 13, ABOVE, IS ALSO ACCEPTABLE
5. TORQUE JAM NUT TO 660-980 IN-LBS AND SAFETY LOCKWIRE PER MS 33540.

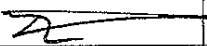
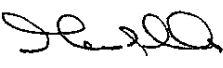
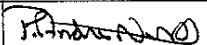

**FIGURE 1**

**DISPOSITION AUTHORIZATION**

ENGINEERING	NAME (PRINT) RAMAN MALIK	SIGNATURE 	DATE(Y/M/D) 2007/09/13	AUTHORIZED ENGINEER OR HIGHER ENGINEERING AUTHORITY    DATE: Sept 13, 2007
STRESS	A. NORTH		2007/09/13	
OTHER (SPECIFY)	M. PERRELLA		2007/09/13	
				<b>Page 4 of 7</b>





		<b>SERVICE CONCESSION REQUEST</b>			SCR NUMBER	REV	PROG
					SCR 086-07	B	2130
		AIRCRAFT DETAILS			INDICATE IF <b>A.O.G.</b> >> <input checked="" type="checkbox"/> <<		
EVENT DATE (Y/M/D)	AIRLINE	A/C S/N	TSN	CSN			
ANY	ALL	4001 AND SUB					
ITEM	PART NO.	NAME			S/N	TSN	CSN
N.H.A ⇨							
N.H.A ⇨	46550-7/-9	RETRACTION ACTUATOR			ALL		
PART ⇨	46570-1/-3	PISTON			ALL		

**INSTRUCTIONS / CONTINUATION SHEET**

**SECTION B**

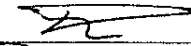
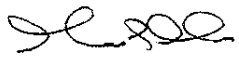
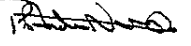
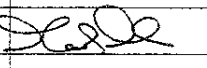
1. MASK AS REQUIRED TO PROTECT ACTUATOR HOUSING, GLAND AREA, AND EXPOSED CHROME OF PISTON FROM F.O.D CONTAMINATION AND DAMAGE DURING THE FOLLOWING REWORK.
2. CHASE PISTON THREADS AND THREAD RELIEF AREA TO REMOVE CORROSION PRODUCTS TO THE GREATEST POSSIBLE EXTENT USING THREAD COMB AND/OR STAINLESS STEEL WIRE BRUSH.
3. INSPECT THE ENTIRE PROFILE OF THREADS OVER THE FULL SPAN OF THREADS (REF. 1.836 DIM, FIGURE 1) AND THE RELIEF GROOVE IN PISTON USING SMALL MIRROR (10X MAGNIFICATION) UNDER ADEQUATE LIGHTING CONDITIONS.
4. **ACCEPTANCE CRITERIA/REWORK OPTIONS**
  - A) LIGHT SURFACE CORROSION (NO PITTING) OVER THE ENTIRE THREADED LENGTH WITH AT LEAST FIVE CONSECUTIVE FULL UNDAMAGED THREADS WITHIN THE ENGAGED THREAD LENGTH (REF FIGURE 2) IS ACCEPTABLE FOR **1000 FC OR 6 MONTHS** (WHICH EVER OCCURS FIRST) OF CONTINUED SERVICE. THE RETRACT ACTUATOR IS TO BE INSPECTED TO ENSURE JAM NUT IS SECURE AND WIRE LOCK IS IN PLACE EVERY **100 FC**
  - B) EVIDENCE OF MODERATE PITTING CORROSION CAN BE REWORKED:
    - a. TO DWG S2116 (HELICOIL SOLUTION). HELICOIL REWORK IS ACCEPTABLE FOR **1000 FC OR 6 MONTHS** (WHICH EVER OCCURS FIRST) OF CONTINUED SERVICE.
    - b. TO DWG S2117 (DOWEL PIN SOLUTION) PROVIDED THAT ~~AN ESTIMATED~~ HALF OF THE ENGAGED THREAD VOLUME (I.E. AT LEAST THE EQUIVALENT OF 7 THREADS) REMAIN. DOWEL PIN REWORK IS ACCEPTABLE FOR **500 FC OR 3 MONTHS** (WHICH EVER OCCURS FIRST) OF CONTINUED SERVICE. **DAILY VISUAL INSPECTION** OF PIN TO ENSURE RETENTION AND ACTUATOR EXTERNAL LEAKAGE IS ALSO REQUIRED
    - c. REPLACED

DISPOSITION AUTHORIZATION				
	NAME (PRINT)	SIGNATURE	DATE(Y/M/D)	AUTHORIZED ENGINEER OR HIGHER ENGINEERING AUTHORITY
ENGINEERING	RAMAN MALIK		2007/09/13	 DATE: Sept 13, 2007
STRESS	A. NORTH		2007/09/13	
OTHER (SPECIFY)	M. PERRELLA		2007/09/13	
				<b>Page 5 of 7</b>





		<b>SERVICE CONCESSION REQUEST</b>			SCR NUMBER	REV	PROG
					SCR 086-07	B	2130
AIRCRAFT DETAILS					INDICATE IF <b>A.O.G.</b> >>> <input checked="" type="checkbox"/> <<<		
EVENT DATE (Y/M/D)	AIRLINE	A/C S/N	TSN	CSN			
ANY	ALL	4001 AND SUB					
ITEM	PART NO.	NAME			S/N	TSN	CSN
N.H.A ⇨							
N.H.A ⇨	46550-7/-9	RETRACTION ACTUATOR			ALL		
PART ⇨	46570-1/-3	PISTON			ALL		
OTHER (SPECIFY)	M. PERRELLA		2007/09/13	DATE:			
<b>Page 6 of 7</b>							

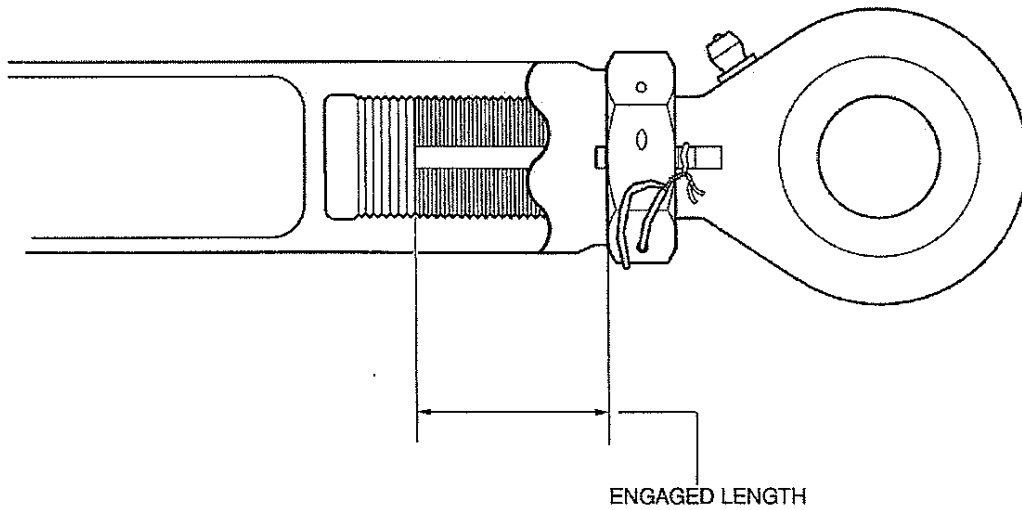

**INSTRUCTIONS / CONTINUATION SHEET**

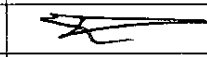
FOR OPTIONS a) AND b), THE RETRACT ACTUATOR IS TO BE INSPECTED TO ENSURE JAM NUT IS SECURE AND WIRE LOCK IS IN PLACE EVERY **100 FC**.

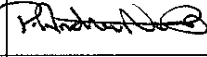

**FIGURE 2**

DISPOSITION AUTHORIZATION				
	NAME (PRINT)	SIGNATURE	DATE(Y/M/D)	AUTHORIZED ENGINEER OR HIGHER ENGINEERING AUTHORITY
ENGINEERING	RAMAN MALIK		2007/09/13	 DATE: Sept 13, 2007
STRESS	A. NORTH		2007/09/13	
OTHER (SPECIFY)	M. PERRELLA		2007/09/13	
				<b>Page 6 of 7</b>

		<b>SERVICE CONCESSION REQUEST</b>			SCR NUMBER	REV	PROG
					SCR 086-07	B	2130
AIRCRAFT DETAILS					INDICATE IF <b>A.O.G.</b> 		
EVENT DATE (Y/M/D)	AIRLINE	A/C S/N	TSN	CSN			
ANY	ALL	4001 AND SUB					
ITEM	PART NO.	NAME			S/N	TSN	CSN
N.H.A ⇌							
N.H.A ⇌	46550-7/-9	RETRACTION ACTUATOR			ALL		
PART ⇌	46570-1/-3	PISTON			ALL		

**INSTRUCTIONS / CONTINUATION SHEET**

SUGGESTED LIST OF CIC SUPPLIERS:

CORBAN 27L      <http://www.zipchem.com/locations.aspx>

MASTINOX 6856K      <http://www.ppg.com/prc-desoto/main.asp?img=crt&contLvl=mansites>

DEFINITIONS

SURFACE CORROSION : a uniform loss of metal due to corrosion

PITTING CORROSION : a localized attack which results in a depression or a pit

**DISPOSITION AUTHORIZATION**

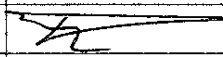
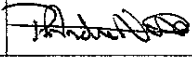
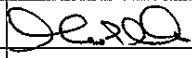
	NAME (PRINT)	SIGNATURE	DATE(Y/M/D)	AUTHORIZED ENGINEER OR HIGHER ENGINEERING AUTHORITY    DATE: Sept 13, 2007
ENGINEERING	RAMAN MALIK		2007/09/13	
STRESS	A. NORTH		2007/09/13	
OTHER (SPECIFY)	M. PERRELLA		2007/09/13	
				<b>Page 7 of 7</b>

